

# PIONEER®



## SOLID STATE AM-FM STEREO RECEIVER MODEL **SX-770**

### CAUTION

Before connecting the line cord to the wall socket, carefully read and follow the instructions described below, to assure the safety of your unit.

- o This receiver is set for 240V operation when shipped. If this unit is used in a different line-voltage area, read and follow "LINE VOLTAGE SELECTION AND FUSE" on page 1. Be sure that the line voltage setting on your unit agrees with the line voltage in your area and that the fuse installed in your unit is a proper one.

### INSTALLATION, OPERATING AND SERVICE MANUAL

Including PARTS LIST, CIRCUIT DIAGRAMS AND MOUNTING TEMPLATE. (FVW)



**PIONEER ELECTRONIC CORPORATION**

## FEATURES

### o LOW-NOISE FET IN FM SECTION

Coupled with the use of a low-noise FET, the FM section is designed for a high sensitivity to obtain a sufficient signal-to-noise ratio.

### o EXCELLENT SELECTIVITY

The IF amplifier stage uses a combination of a low-noise silicon transistor and a monolithic IC to attain an excellent selectivity characteristic.

### o MONOLITHIC IC FOR MPX SECTION

The MPX section is an IC for a stable, wide frequency band and a sharp channel separation. A sufficient measure is taken against SCA beat.

### o HIGHLY SENSITIVE AM TUNER

Due to the silicon transistor and ferrite antenna, the AM tuner has a high and stable sensitivity.

### o MICROPHONE TERMINAL FOR A VERSATILITY OF USE

Input terminals include a magnetic-cartridge record player terminal and a microphone terminal. Output terminals include a center channel terminal and a preamplifier terminal. Thus Model SX-770 can be used in various ways.

### o WELL DAMPED, CLEAR SOUND

The output stage is a quasi-complementary SEPP circuit using silicon transistors. Model SX-770 reproduces well-damped, clear stereo sound over a wide frequency range from bass to treble.

### o VARIETY OF ACCESSORY CIRCUITS

Accessory circuits include an FM AFC circuit, muting circuit, high-cut filter, tape monitor, loudness contour switch, etc.

### o NOVEL APPEARANCE

In addition to the black panel, the numeral indication is embossed on the dial plate according to the selected position. Also, the dial pointer glows.

## LINE VOLTAGE SELECTION AND FUSE

### SWITCHING LINE VOLTAGE SETTING AND FUSE

In order to remove the fuse, turn the fuse cap located on the line voltage selector switch in the direction indicated by an arrow. Then remove the fuse plug from the unit. Put the fuse plug back so that the proper line voltage marking can be seen through the cut in the edge of the plug. Whenever the set position of the selector switch is changed, check the rating of the fuse. A 1-ampere fuse is to be used for either 220V or 240V operation and a 2-ampere fuse for any of 110V, 117V, or 130V operation. If the rating of the fuse is proper, install the fuse in the fuse cap.

### REPLACING OF FUSE

When the fuse is blown, remove the fuse cap and replace the fuse with a new one.

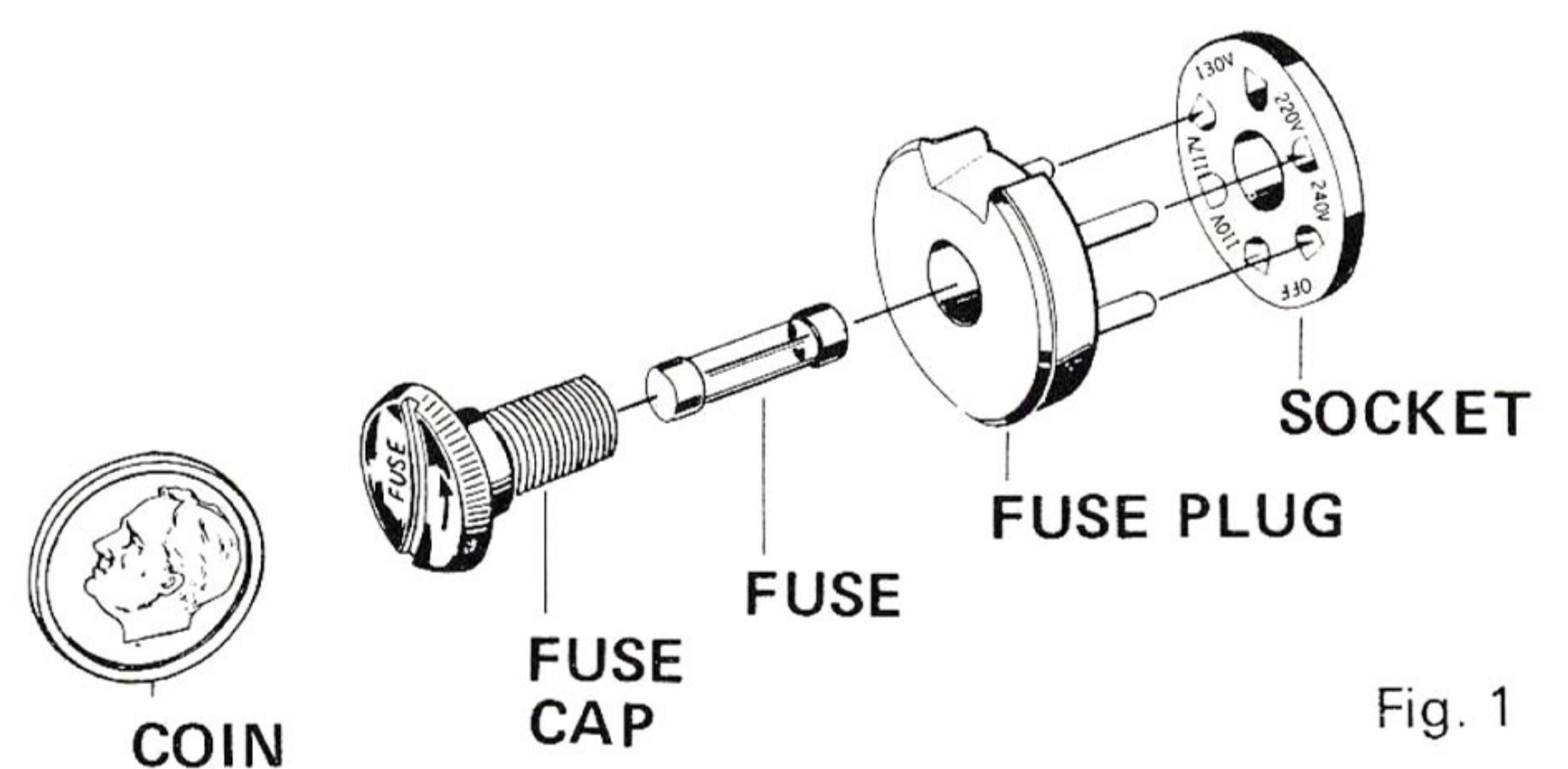
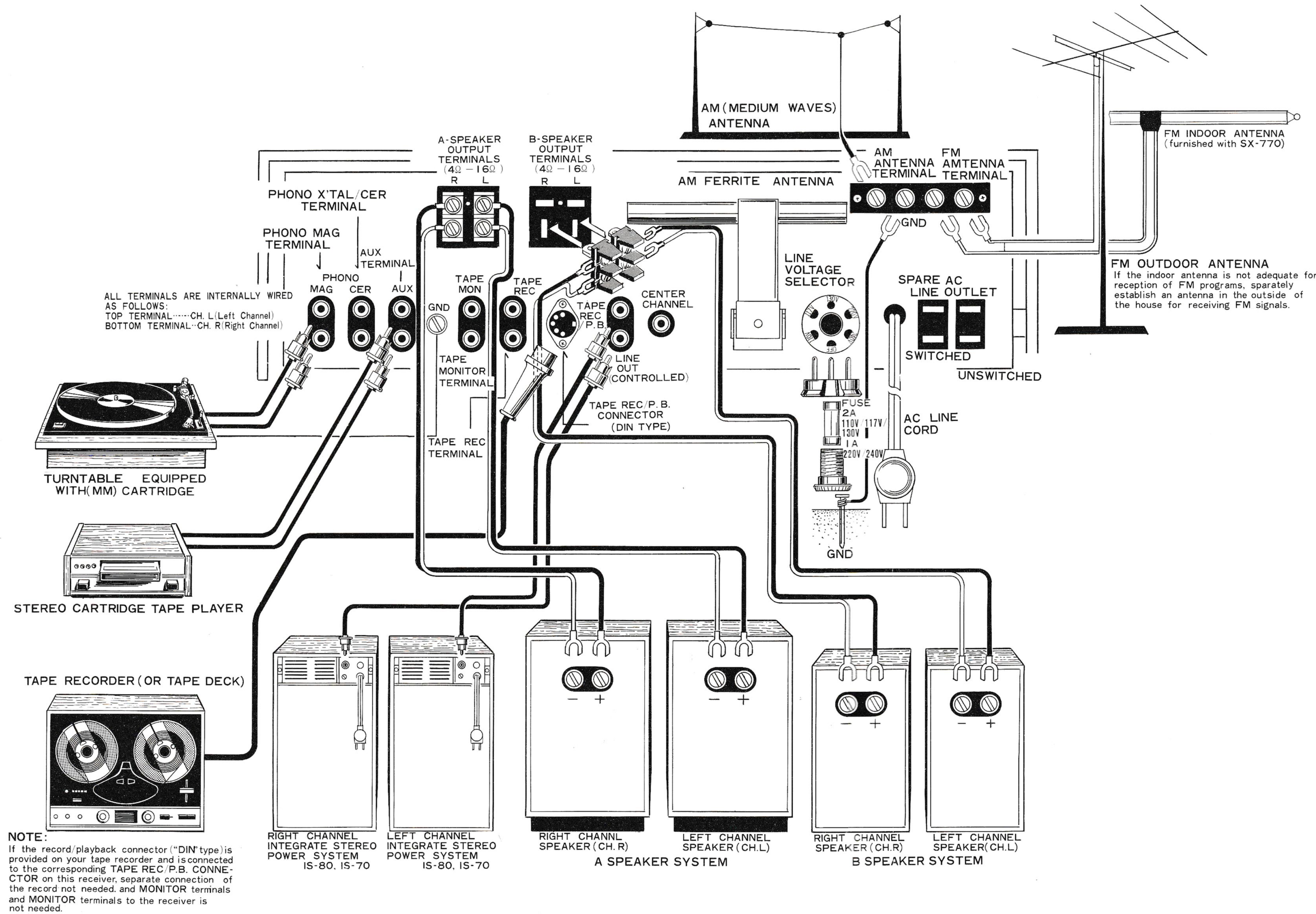

Fig. 1

Take off the fuse cap by turning it with a coin, etc. in the direction indicated by the arrow mark.

## REAR CONNECTIONS



## STEREO SYSTEM

This receiver is a general-purpose stereo amplifier. Connect to it the loudspeaker systems (two or four), record player, tape recorder, etc., which are separately available.

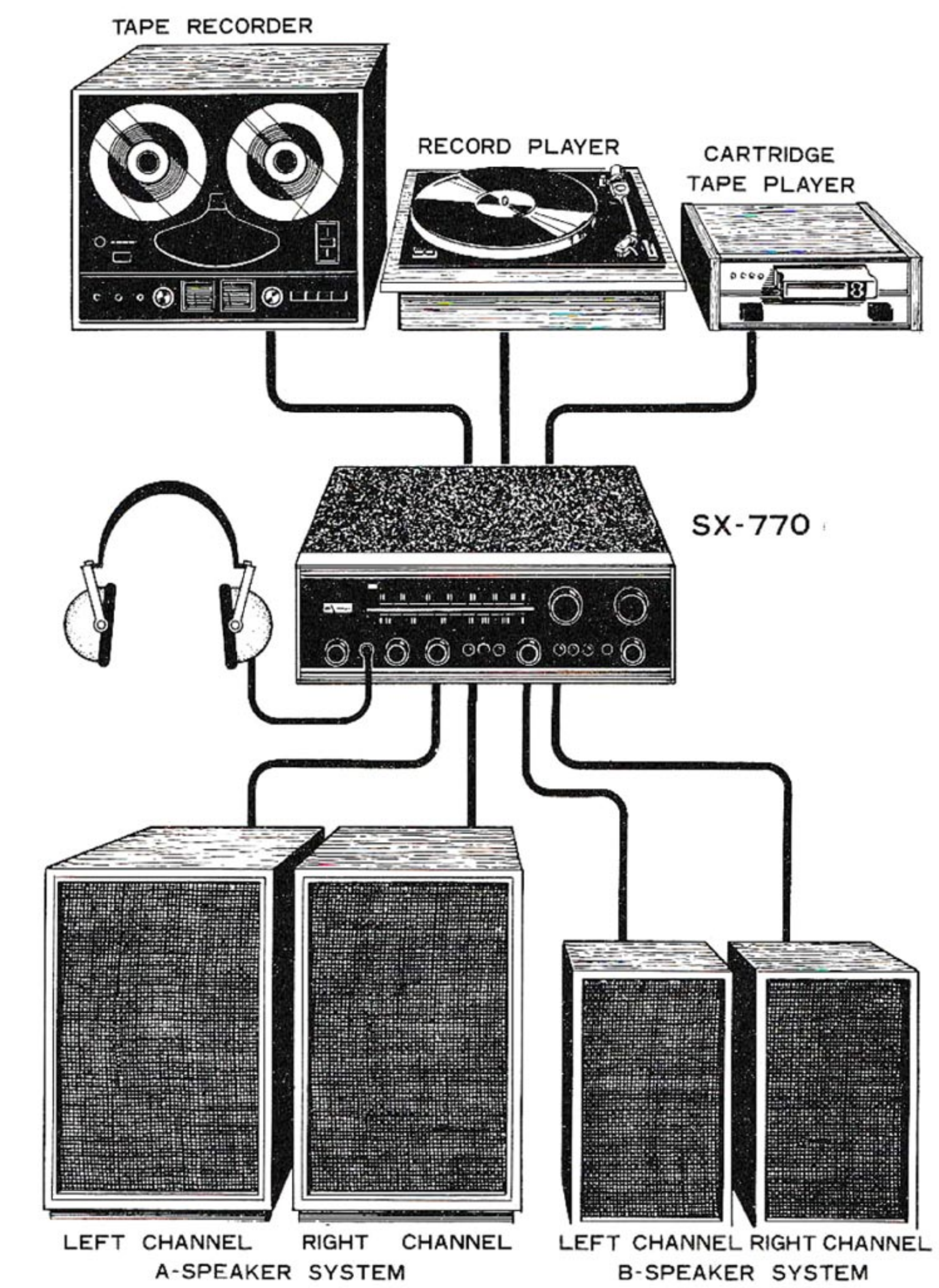

Fig. 3

## INSTALLATION

For installation of the stereo system, select a place meeting the following.

- o Well ventilated, and free from moisture and dust.
- o Unexposed to direct sunlight.
- o Far from heat radiators (space heaters, etc.).
- o Stable without incurring vibrations.

## LISTENING ROOM

- o When the stereo system is installed, listen to music according to the connection and operation instructions described below.
- o The reproduced sound is very different depending on the size of the room, the furniture arrangement in the room, and the materials of walls, floor and ceiling. Generally, the reproduced sound fills the room if the room has a low ceiling and hard floor, or the room has a small length and a hard wall opposing loudspeakers. This undesirable acoustic condition can be much alleviated by laying a carpet on the floor for the former room and by covering the wall with a thick curtain for the latter room. It is also an effective solution to change the arrangement of furniture for irregular reflection of the loudspeaker sound.

Fig. 2

## PROGRAM INDICATOR LAMP

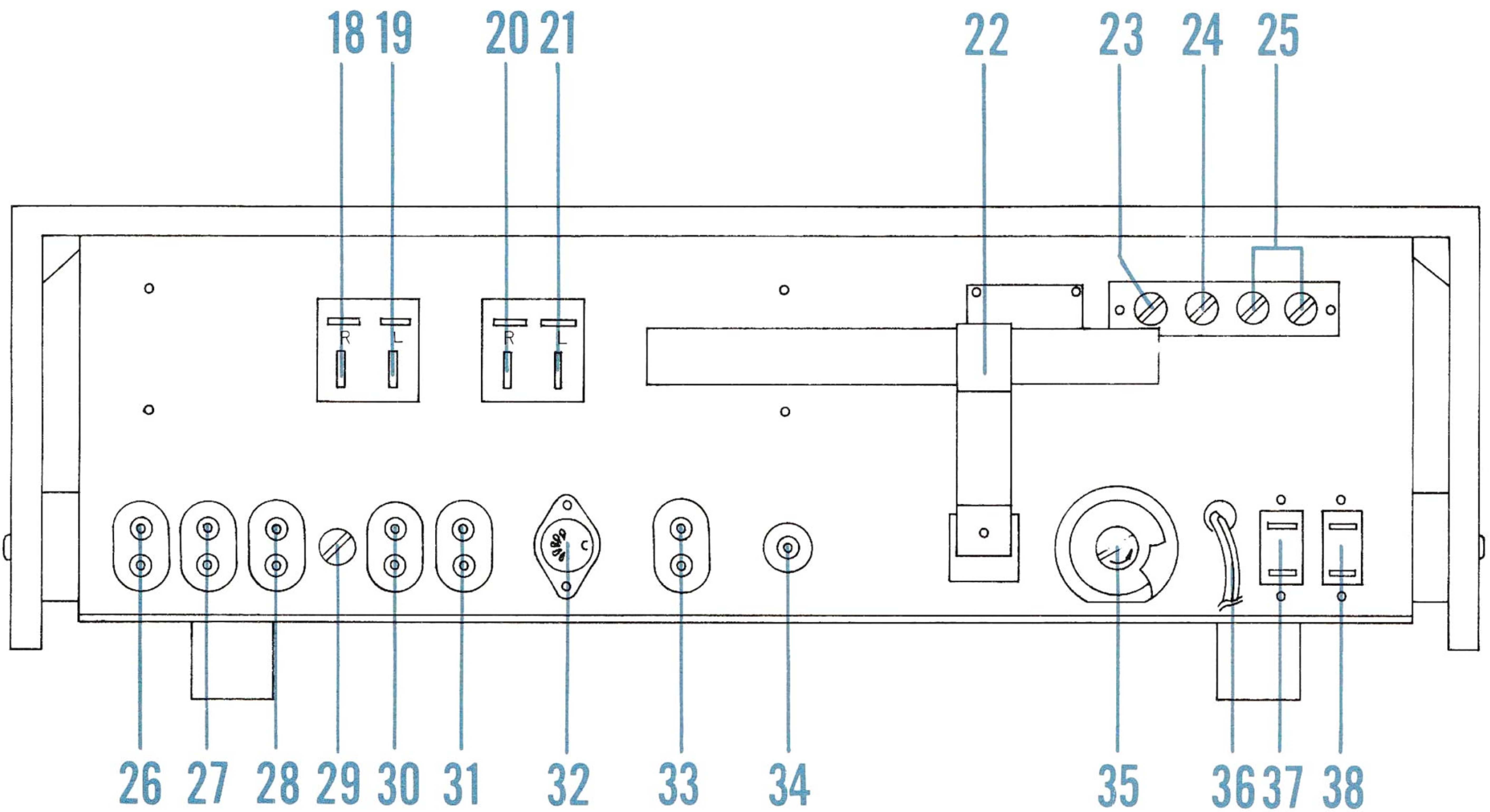
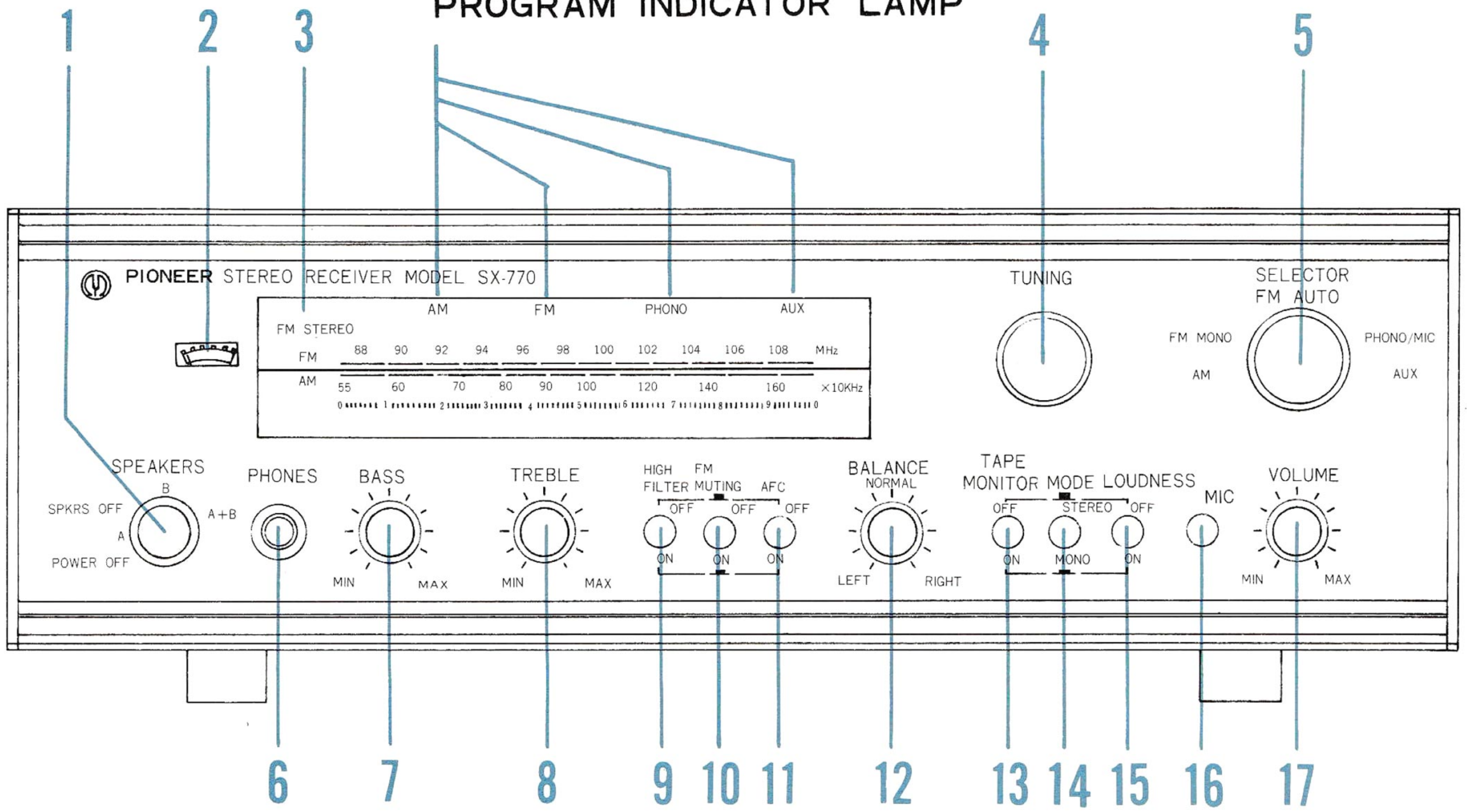



# KNOB AND SWITCHES ON FRONT PANEL

## 1. SPEAKERS (POWER SUPPLY AND LOUDSPEAKER) SWITCH

This knob turns off the power supply, and selects the loudspeaker output terminals. The function at each position of the knob is as follows:

- POWER OFF Model SX-770 is deenergized.
- SPKR'S A Loudspeaker output terminals A are operative.
- SPKR'S OFF Both loudspeaker output terminals A and B are inoperative. This position is selected when using a stereo headphones.
- SPKR'S B Loudspeaker output terminals B are operative.
- SPKR'S A + B Both loudspeaker output terminals A and B are operative.

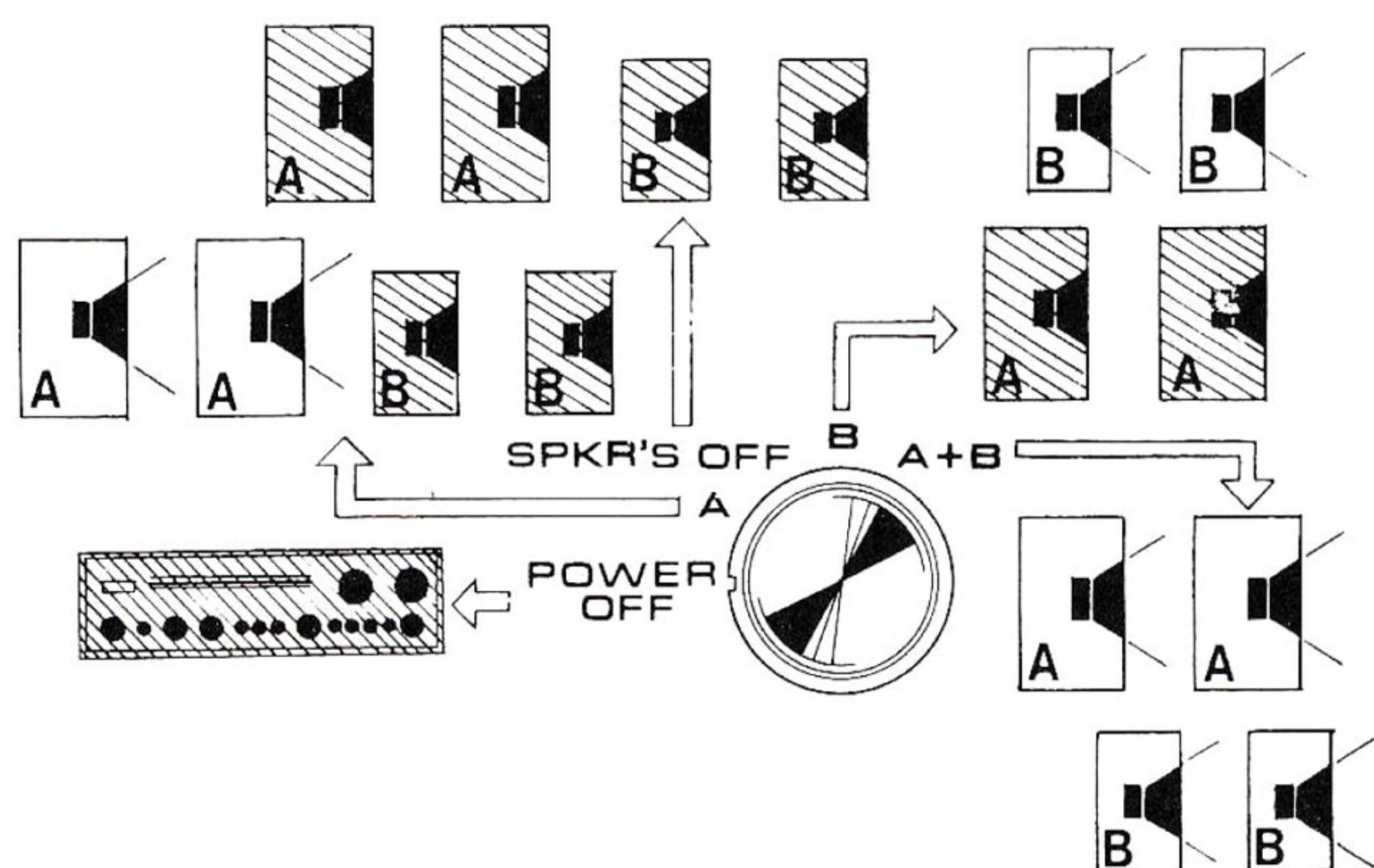

Fig. 4

## 2. TUNING INDICATOR

When tuning the radio receiver to an FM or AM broadcast station, the TUNING KNOB (4) is adjusted so that the pointer of this meter may deflect to the maximum.

## 3. FM STEREO INDICATOR

When the receiver receives an FM stereo program, this lamp lights.

## 4. TUNING KNOB

An AM or FM broadcasting station is tuned in. While observing the pointer of the TUNING INDICATOR (2), set the knob for the best receiving condition.

## 5. SELECTOR SWITCH

This switch is used to select a broadcast reception mode or the record playing mode:

- AM For reception of an AM (medium wave) broadcast program.
- FM MONO For reception of a monaural FM broadcast program.
- FM AUTO For reception of an FM broadcast program, automatically switching the receiver for stereo or monaural mode.
- PHONO/MIC Sets the equipment for playing a disc record and microphone.
- AUX Sets the equipment for reproducing the auxiliary input signal.

When the SELECTOR switch is operated, the program indicator lamp corresponding to the selected source lights.

## 6. PHONES

Cord plug of a stereo headphone is inserted here for enjoying stereo play without disturbing other people around. Loudspeakers stop emitting sound then. For the stereo headphone, PIONEER's Model SE-2P, SE-20, SE-30 or SE-50 is recommended.

- o When a longer cord is required for the stereo headphones, use PIONEER's Model JB-23 extension cord separately available.
- o When desiring to connect two stereo headphones, use PIONEER's Model JB-22 "Y" cord separately available.

## 7. BASS CONTROL

As this knob is turned clockwise, bass is boosted; as turned counterclockwise, attenuated. The control is designed to give a flat characteristic curve when the knob is set to the middle of the rotation range.

- o This knob controls the tone quality of both right and left channels simultaneously.

## 8. TREBLE CONTROL

Use of this treble control knob is similar to that of the BASS CONTROL KNOB (7)

## 9. HIGH FILTER SWITCH

When this switch is turned on, high-frequency noise, such as scratch noise, will be cut off.

## 10. FM MUTING SWITCH

Turn on this switch when desiring to eliminate the noise between stations while tuning in an FM broadcast program. Keep this switch turned off when tuning in a remote station.

## 11. AFC SWITCH

Keep this switch turned on when listening to an FM broadcast program. To tune in the FM broadcast station more accurately, turn off this switch, tune in the station, then turn on the switch when the station has been tuned in.

## 12. BALANCE CONTROL

When the knob is turned toward RIGHT, the center of loudspeaker sound moves rightward; when turned toward LEFT, leftward.

## 13. TAPE MONITOR SWITCH

For ordinary record play or radio reception, keep this switch in the "OFF" position.

Set the switch to "ON" only when playing back a tape by using a tape recorder (or tape deck) or monitoring the recording condition of such equipment. If the switch is set to the "ON" position when conducting disk record play or radio reception, loudspeakers do not sound. Be careful in this respect.

## 14. MODE SWITCH

When playing a disk record or tape, or receiving a broadcast program, keep this switch in the "STEREO" position. Set the switch to "MONO" only when using a monaural record player or tape recorder, or reproducing a tape on which monaural recording is made.

## 15. LOUDNESS CONTOUR SWITCH

When the switch is set to the "ON" position while the receiver is operated at a low sound volume, both bass and treble are boosted for easy listening. When the equipment is operated at a high sound volume, it is recommended to keep the switch in the "OFF" position.



## 16. MIC JACK

When using a microphone, connect the microphone output to this jack. The loudspeakers stop emitting the sound from the turntable, when the microphone is connected to the jack.

NOTE: Set the VOLUME control (17) to the MIN position before inserting the microphone into the jack.

## 17. VOLUME CONTROL

The loudspeaker sound volume increases when this knob is turned clockwise; it decreases when the knob is rotated counterclockwise.

# TERMINALS AND CONNECTION ON REAR PANEL

## 18 & 19. SPEAKER SYSTEM A TERMINALS

Two speaker systems A and B can be connected to the receiver, and they can be selectively used by operating the switch (1). Connect the right channel loudspeaker of the first speaker systems to terminals (18) and the left channel loudspeaker to terminals (19).

## 20 & 21. SPEAKER SYSTEM B TERMINALS

When using two speaker systems, use these terminals (20) and (21) for the second systems. Connect the loudspeaker for the right channel to terminals (20) and those for the left channel to terminals (21).

NOTE: For connection of loudspeakers to these terminals, the plugs contained in the accessory bag must be used. For correct loudspeaker connection, refer to the article "CONNECTION OF LOUDSPEAKER SYSTEMS".

## 22. AM FERRITE ANTENNA

An AM broadcast receiving antenna accessory to the SX-770. When using the SX-770 where the field intensity is high, reception can be conducted simply by adjusting the direction of this antenna without connecting an external antenna to the AM ANTENNA TERMINAL (23).

## 23. AM ANTENNA TERMINAL

This terminal is provided for connecting an external AM broadcast receiving antenna.

## 24. GROUND TERMINAL 1

Connect a ground conductor to this terminal for grounding the receiver.

## 25. FM ANTENNA TERMINALS

An FM broadcast receiving antenna will be connected to these terminals.

NOTE: For the most suitable FM antenna, AM antenna and grounding, refer to the article "ANTENNA CONNECTION AND GROUNDING".

## 26. PHONO MAGNETIC TERMINALS

Connect here the output cords of a turntable equipped with a magnetic cartridge. The upper jack is for the left channel; the lower jack, for the right channel. When connecting a monaural turntable, use the upper jack.

## 27. PHONO CER TERMINALS

Connect here the output cords of a turntable equipped with a ceramic cartridge. The upper jack is for the left channel; the lower jack, for the right channel. When connecting a monaural turntable, use the upper jack.

## 28. AUXILIARY TERMINALS

These jacks are used when connecting the output cords of a cartridge tape player. Also use these jacks for reproducing the audio output of a TV receiver. The upper jack is for the left channel; the lower jack, for the right channel.

## 29. GROUND TERMINAL 2

If the turntable or other equipment to be used with the receiver has a ground conductor, connect it to this terminal.

## 30. TAPE MONITOR TERMINALS

Connect to these jacks the playback output terminals (line output) or monitor terminals of the tape recorder (or tape deck) used with the receiver.

## 31. TAPE RECORDING TERMINALS

Connect to these jacks the recording input terminals (line input) of the tape recorder (or tape deck). The signals outgoing from these terminals cannot be adjusted with the VOLUME (17), BASS (7) or TREBLE (8) controls.

NOTE: For correct connection to the TAPE MONITOR (30) and TAPE RECORDING (31) jacks, refer to the article "CONNECTION OF TAPE RECORDER".

## 32. TAPE RECORDING / PLAYBACK CONNECTOR (DIN TYPE)

Provided that the tape recorder (or tape deck) to be used has a DIN-type tape recording/playback connector, connection for recording and playback (and monitor) can be completed simply by linking the tape recorder with the receiver through the recording/playback cord that is separately available. When this connector is used, terminals (30) and (31) are not used.

## 33. LINE OUTPUT TERMINALS (CONTROLLED)

These are the preamplifier output terminals. They are used when using a power system (Model IS-80 or IS-70) of PIONEER's integrate stereo equipment. Also, a high-power stereo system can be composed by connecting other high-power amplifier to these terminals.

## 34. OUTPUT TERMINAL

This is the output terminal of right and left channels mixed together. To this terminal, a center channel loudspeaker or the monaural power amplifier for a 3D system will be connected.

## 35. LINE VOLTAGE SELECTOR AND FUSE HOLDER

This selector is used for setting the receiver to suit the line voltage to be supplied. It also serves as a fuse holder. For the selector setting and fuse replacement procedures, refer to the article "LINE VOLTAGE SELECTION AND FUSE". (Page 1)

## 36. AC CORD

After correctly setting the LINE VOLTAGE SELECTOR (35), connect this cord to an outlet of the commercial power line.

## 37. AC OUTLET (SWITCHED)

The power obtained from this AC outlet is turned ON and OFF interlinked with the operation of SPEAKER SWITCH (1). A maximum of 120VA can be supplied to the turntable or other equipment connected.

## 38. AC OUTLET (UNSWITCHED)

An AC outlet having a capacity of 200 VA. This power outlet is not interlinked with the operation of SPEAKER SWITCH (1).

## CONNECTION OF LOUDSPEAKER SYSTEMS

- o When connecting loudspeakers, extract speaker connector plug from the accessory bag and connect the speaker wire leads to the plugs as illustrated below. Be sure to connect the positive of the leads to the positive terminal of the plug.
- o When the loudspeakers are connected to the plugs, insert the right channel speaker plug into the speaker system A terminal socket (18) and the left channel speaker plug into the speaker system A terminal socket (19). (Refer to the connection diagram shown in page 2).
- o When using two speaker systems, connect the wire leads of the second speaker system to speaker plugs as described above, and insert the right channel speaker plug of this speaker system into the speaker system B terminal socket (20) and the left channel speaker plug into the speaker system B terminal socket (21).

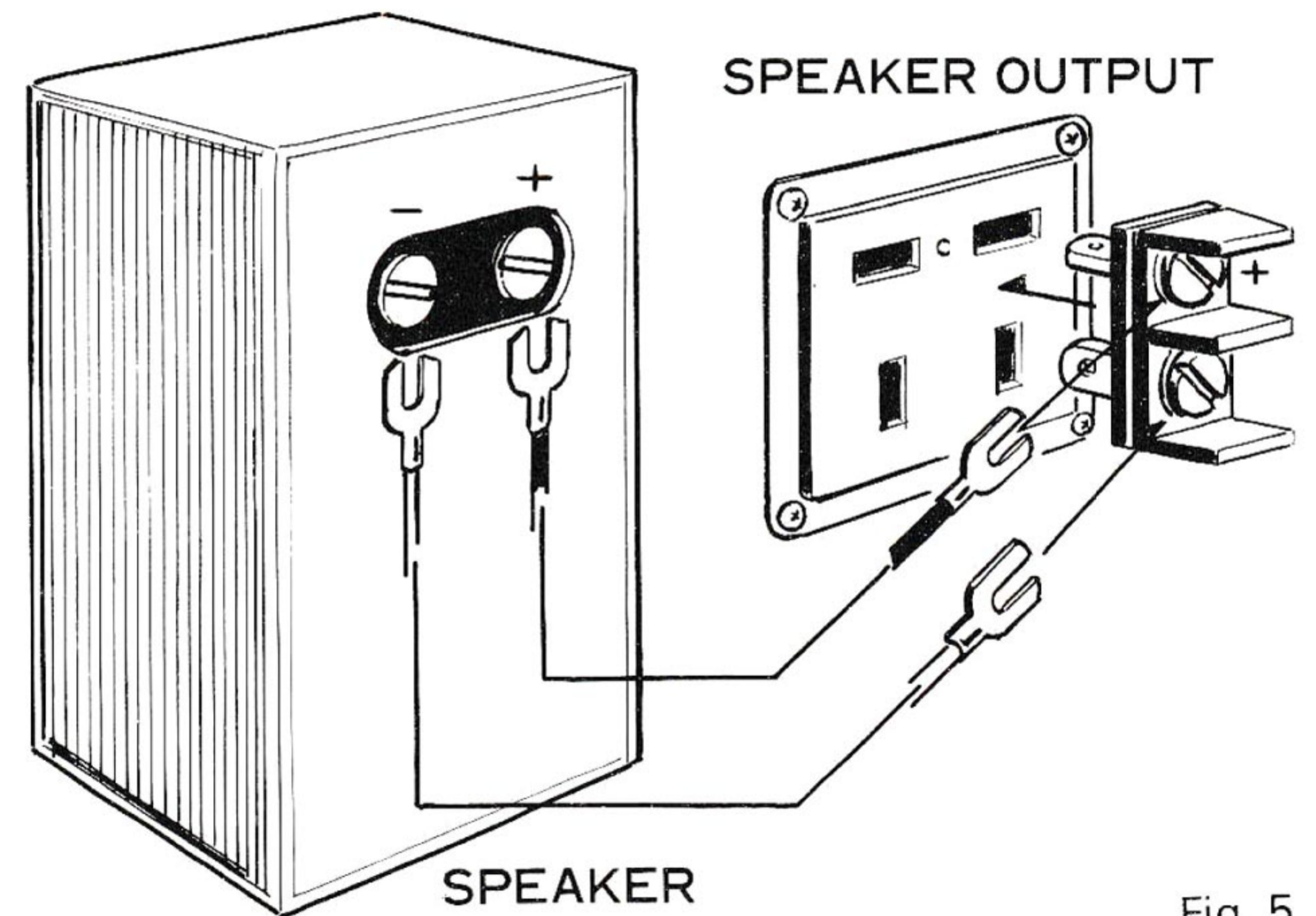

Fig. 5

## ANTENNA CONNECTION AND GROUNDING

### FM BROADCAST RECEIVING ANTENNA:

The field strength of FM broadcast is much attenuated behind mountains and buildings, and in ferroconcrete buildings. This requires to use an FM antenna of different type depending on the area and place where the receiver will be used. Use the most suitable antenna, referring to the following:

- \* Employ the T-type indoor antenna accessory to the receiver when using the receiver within a wooden building near the FM radio station. Connect the end of the vertical section of the T-type antenna to the FM ANTENNA TERMINALS (25) as shown in Fig. 6, and expand the horizontal section of the T-type antenna. While actually receiving broadcast, determine the direction of the horizontal section for the best radio reception and fix it on a wall or other place. Refer to the article "RECEPTION OF FM BROADCAST" regarding the determination of the antenna direction.
- \* When using the receiver far from the broadcasting station, behind a mountain or within a ferroconcrete building, install an FM radio antenna (or FM/TV common antenna) outdoors and connect it to the FM antenna terminals (25). The FM antenna is various in type, having 3 to 7 elements. Select the most suitable antenna by consulting a nearby radio antenna sales store.

NOTE: The installation procedure of FM radio antenna is similar to that of TV antennas. For details, follow the instructions accompanying the FM radio antenna purchased.

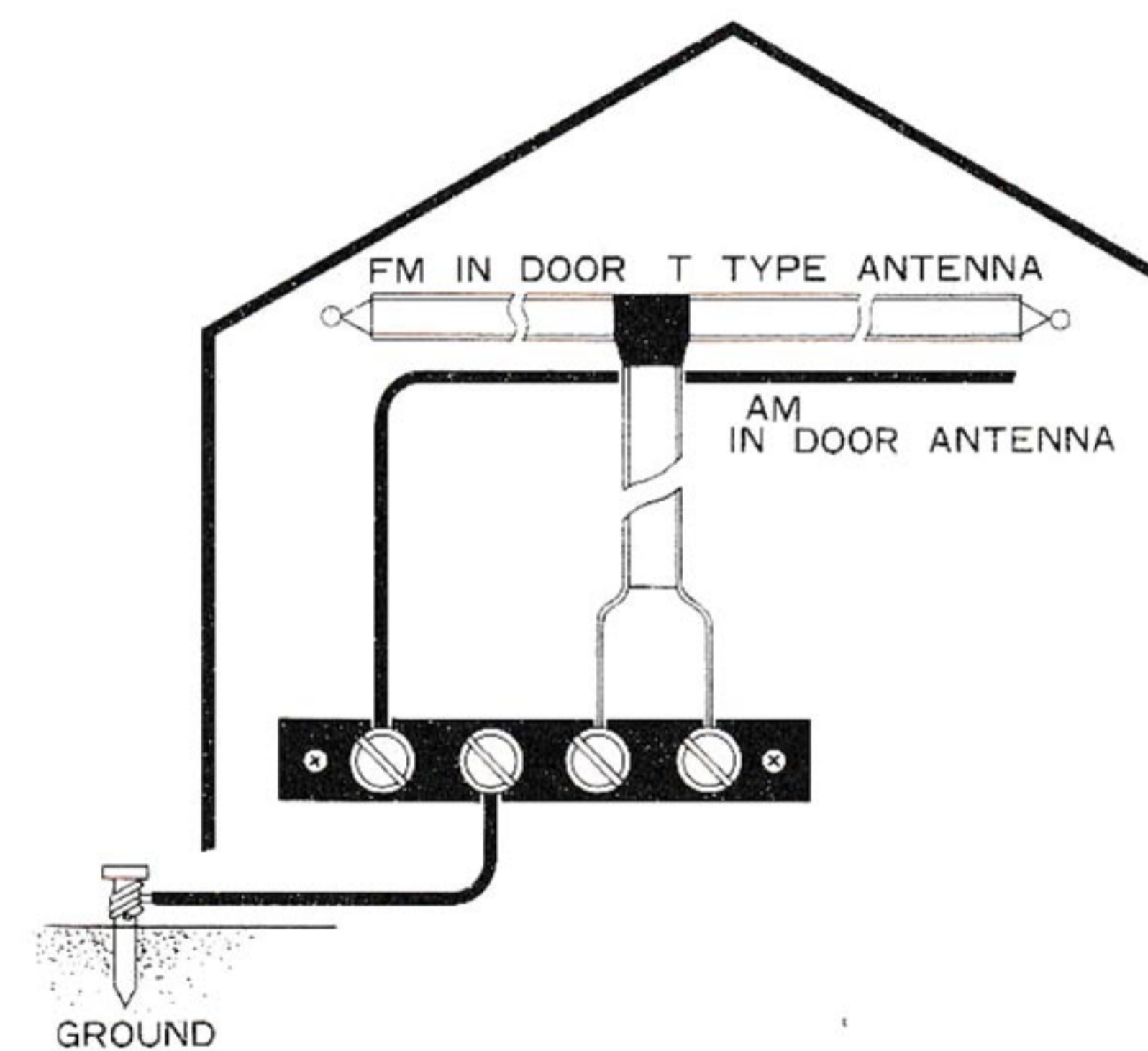

Fig. 6

### AM BROADCAST RECEIVING ANTENNA:

- \* When using the SX-770 near the broadcasting station or inside a wooden building, it is unnecessary to install an AM antenna. In such an area, set the direction of the AM FERRITE ANTENNA for the best radio reception while actually listening to broadcasts. Refer to the article "RECEPTION OF AM BROADCAST"
- \* If good reception cannot be attained even by properly adjusting the direction of the AM FERRITE ANTENNA, use the accessory AM lead wire antenna. Connect one end of the antenna to the AM ANTENNA TERMINAL (23) and expand the wire along a wall of the room.
- \* If good reception cannot be attained even when the accessory lead wire antenna is used, install an AM antenna outdoors. Connect the lead-in wire of the outdoor antenna to the AM ANTENNA TERMINAL (23).

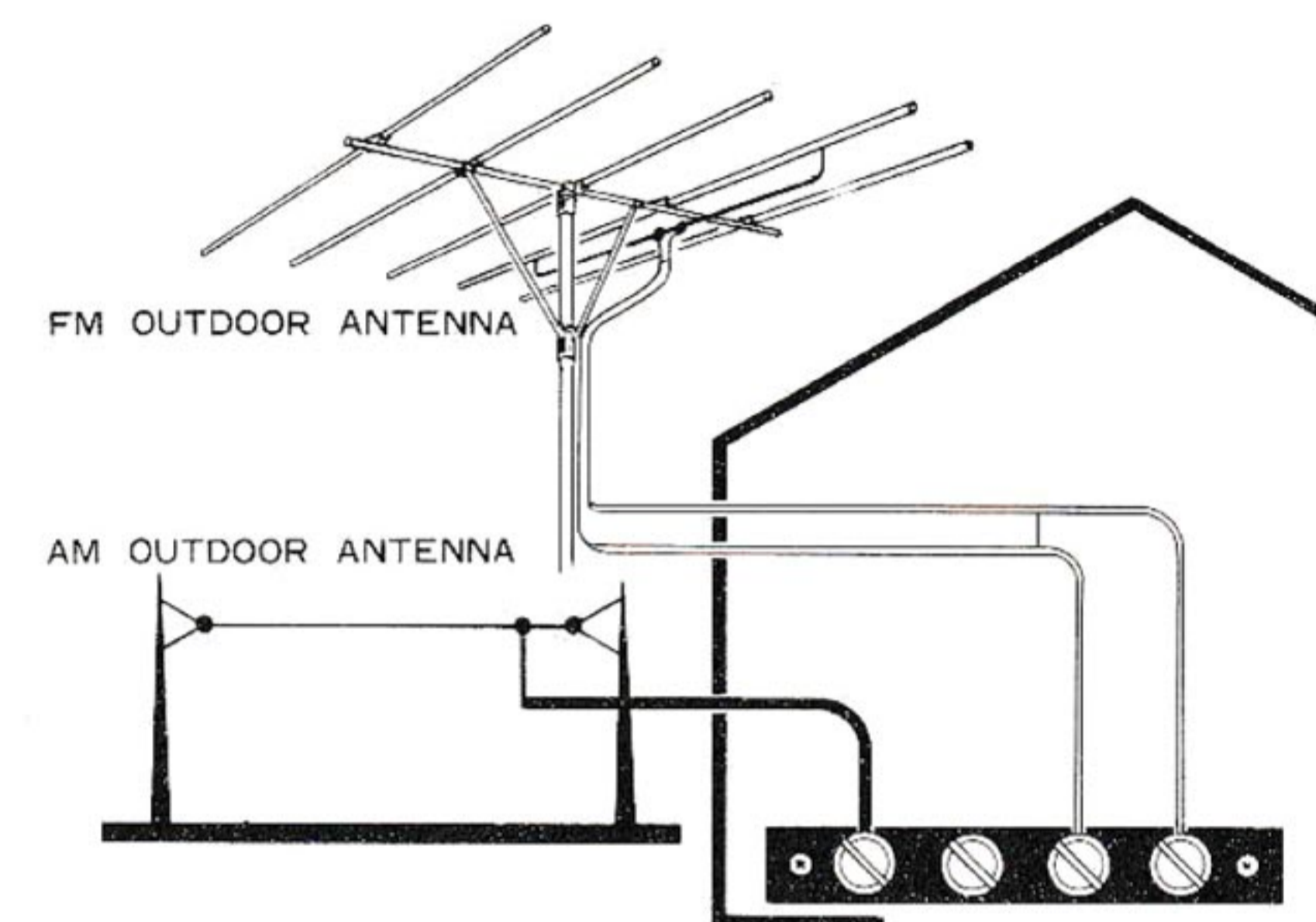

Fig. 7

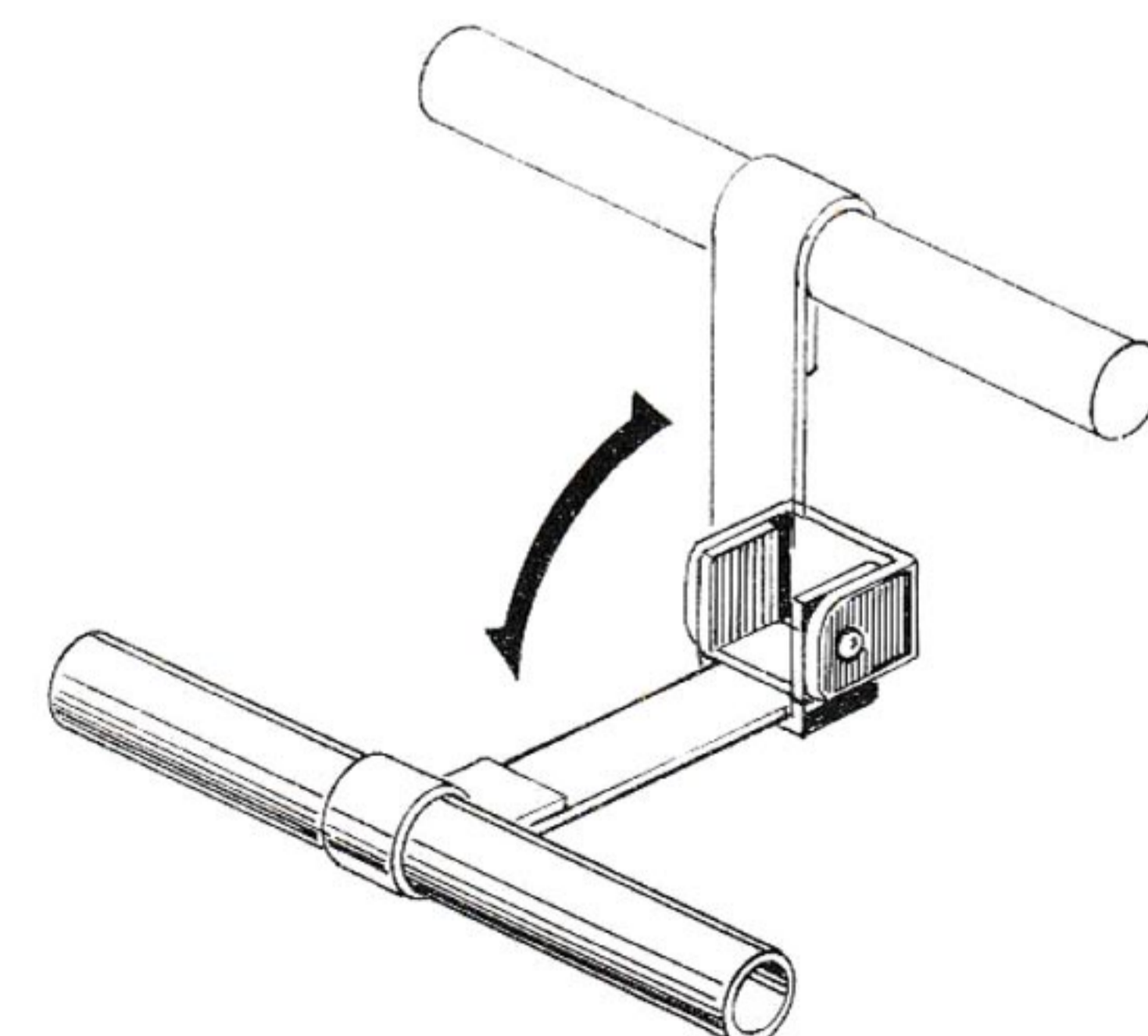

Fig. 8



#### NOTE:

For the outdoor antenna, a standard AM broadcast antenna can be formed by purchasing PVC wire from an electric appliance shop and installing it 25 feet (7.5m) above the ground for a horizontal length of 50 feet (15m), with a feeder line 30 feet (10m) long. These wire lengths may not be so precise and may be as long as allowed by the place of installation. However, the height of the horizontal section of the antenna should not be too low to attain a good antenna effect.

#### GROUNDING:

- \* Grounding or non-grounding the GROUND TERMINAL 1 (24) does not much affect the performance of the receiver. However, it is desirable to ground the terminal from the viewpoint of safety.
- \* Connect to the GROUND TERMINAL 1 (24) the ground conductor leading to the earth.

## CONNECTION OF TURNTABLE

---

- \* If the turntable to be used with the receiver has a magnetic cartridge, connect the output cords of the turntable to the PHONO MAGNETIC TERMINALS (26); if the turntable has a crystal or ceramic cartridge, connect the output cords to the PHONO CER TERMINALS (27). Insert the output cord plug for the left channel into the upper terminal jack, and that for the right channel into the lower terminal jack.

When using a monaural turntable, connect its output cord to the upper (left channel) terminal.

#### NOTE:

If the output cord plug of the turntable to be connected does not fit the input terminal jack of the receiver, replace the plug with the pin plug contained in the accessory bag.

## CONNECTION OF TAPE RECORDER (OR TAPE DECK)

---

- \* The tape recorder to be used with the receiver should have an output terminal (line output) for connection to external amplifier, or a tape monitor terminal.
- \* When using a tape deck, the tape deck should have a recording/playback preamplifier built in. PIONEER's Model T-500 separately available can be used with the receiver without any problems.

#### CONNECTION FOR RECORDING:

Connect the recording input terminals (line input) of the tape recorder (or tape deck) to the TAPE RECORDING TERMINALS (31) of the receiver. For this connection, use the cords which are normally accessory to the tape recorder. The upper one of the recording input terminals (line input) is for the left channel; the lower one, for the right channel. When the tape recorder is monaural, connect its input terminal to the upper TAPE RECORDING TERMINAL (31):

#### CONNECTION FOR PLAYBACK (OR TAPE RECORDING MONITOR):

Connect the playback output terminals (line output or tape monitor terminals) of the tape recorder (or tape deck) to the TAPE MONITOR TERMINALS (30). The connecting procedure is similar to that of the above "CONNECTION FOR RECORDING".

#### o USE OF TAPE REC/P.B. CONNECTOR:

If the tape recorder (or tape deck) to be connected to the receiver has a recording/playback connector of DIN type, connect it to the TAPE REC/P.B. CONNECTOR (32) of the receiver. Disregard "CONNECTION FOR RECORDING" and "CONNECTION FOR PLAYBACK".

## CONNECTION OF CARTRIDGE TAPE PLAYER

When using the cartridge tape player (PIONEER's Model H-60E), connect its output to the AUXILIARY TERMINALS (28). The connecting procedure is similar to that for turn table connection.

## RECEPTION OF BROADCAST

### BEFORE TURNING ON THE SPEAKER SWITCH OF THE RECEIVER, CHECK THE FOLLOWING:

VOLUME CONTROL KNOB (17) is set to "MIN".  
TAPE MONITOR SWITCH (13) is set to "OFF".  
MODE SWITCH (14) set to "STEREO".

### RECEPTION OF FM BROADCAST:

1. Set the SELECTOR knob (5) to the "FM AUTO" position.
2. Set the AFC switch (11) to the OFF position.
3. While observing the pointer deflection of the TUNING INDICATOR (2), tune the receiver to the desired station by using the TUNING knob (4). The best reception is attained when the pointer of the TUNING INDICATOR (2) largely deflects rightward. If the tuned station is broadcasting a stereo program, the STEREO INDICATOR (3) lights. With the SELECTOR knob (5) in this position, monaural programs can also be received.
4. Set the AFC switch (11) to the ON position.
5. When the desired station is tuned in, gently turn the VOLUME CONTROL knob (17) clockwise. Adjust the BASS CONTROL (7) and TREBLE CONTROL (8) for the desired tone quality.
  - \* When the receiver is used very far from the broadcasting station, or external noise is intensive, the noise is suppressed and better reception is attained by setting the SELECTOR knob (5) to the "FM MONO" position. When the knob is in this position, however, stereo programs are received as monaural programs.
6. When good radio reception cannot be attained by the above operating procedures 1 to 5, re-consider the antenna, referring to the article "ANTENNA CONNECTION AND GROUNDING".

### RECEPTION OF AM BROADCAST:

1. Set the SELECTOR knob (5) to the AM position.
2. While observing the pointer deflection of the TUNING INDICATOR (2), tune the receiver to the desired station by using the TUNING knob (4). The best reception is attained when the pointer of the TUNING INDICATOR (2) largely deflects rightward.
3. When the desired station is tuned in, adjust the VOLUME CONTROL (17), BASS CONTROL (7) and TREBLE CONTROL (8) for desired sound volume and tone quality.
4. When good radio reception cannot be attained, such as speaker sound is noisy or inferior in tone quality by the above operating procedures 1 to 3, re-consider the antenna, referring to the article "ANTENNA CONNECTION AND GROUNDING". When the receiver is used very near the broadcasting station, the field intensity is sometimes too strong, resulting in low tone quality. If this occurs, shorten or remove the antenna connected to the AM antenna for the best radio reception.



## PLAY OF DISK RECORD

1. Set the SELECTOR knob (5) to the "PHONO" position.
2. When using a monaural turntable, set the MODE SWITCH (14) to the "MONO" position.
3. Adjust the VOLUME, BASS and TREBLE CONTROLS for desired sound volume and tone quality.

## PLAY OF CARTRIDGE TAPE

1. Set the SELECTOR knob (5) to the "AUX" position.
2. The succeeding procedure is similar to its counterpart of the disk turntable operation.

## RECORDING AND PLAYBACK WITH TAPE RECORDER (OR TAPE DECK)

The same signals as those emitted from loudspeakers can always be taken out from the TAPE RECORDING TERMINALS (31) of the receiver. Operate the SELECTOR knob (5) and MODE SWITCH (14) according to the program source to be recorded, following the instructions described in articles "RECEPTION OF BROADCAST" and "PLAY OF DISK RECORD".

The volume, BASS and TREBLE controls of the receiver cannot be used for the tape recording. The recording level should be adjusted by the control of the tape recorder (or tape deck).

### NOTE:

When using a monaural tape recorder, signals of either left or right channel only can be recorded.

### PLAYBACK

Set the TAPE MONITOR SWITCH (13) to the "ON" position. Adjust the VOLUME, BASS and TREBLE CONTROLS for desired sound volume and tone quality.

\* When the TAPE MONITOR SWITCH (13) is in the "ON" position, the position of the SELECTOR knob (5) is unrelated to the playback operation.

### TAPE MONITOR:

If the tape recorder used with the receiver is provided with a monitor circuit, monitor can be effected regardless of the tape recorder being two-head or three-head type. Connect the tape recorder to the receiver recording and playback terminals. By setting the TAPE MONITOR (13) from "OFF" to "ON" while making recording, the signals applied to the recording head can be monitored if the tape recorder is of the two head system. If a three-head tape recorder is used, recorded signals can be monitored immediately after recording.

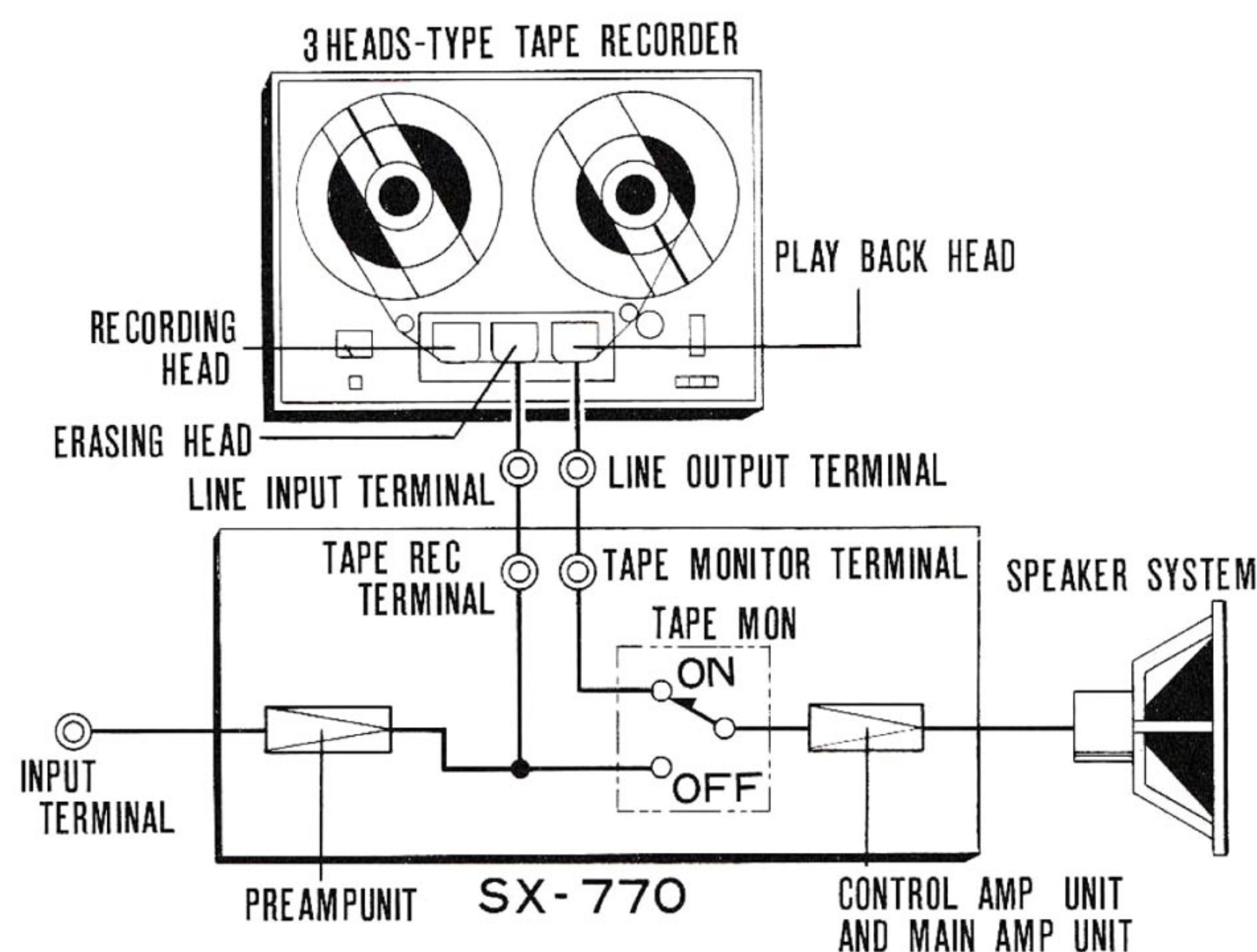

Fig. 9

## MODEL SX-770 IS ALSO USABLE AS FOLLOWS

### By using the center channel output terminal:

#### 1. For prevention of the hole effect:

When employing a three-speaker system to prevent the hole effect which is apt to be caused to the stereo play in a large room, connect an additional power amplifier to this terminal.

#### 2. For bass compensation:

A bass-compensated system can be composed by cutting off the part higher than 250 Hz of the center channel output with a high-cut filter.

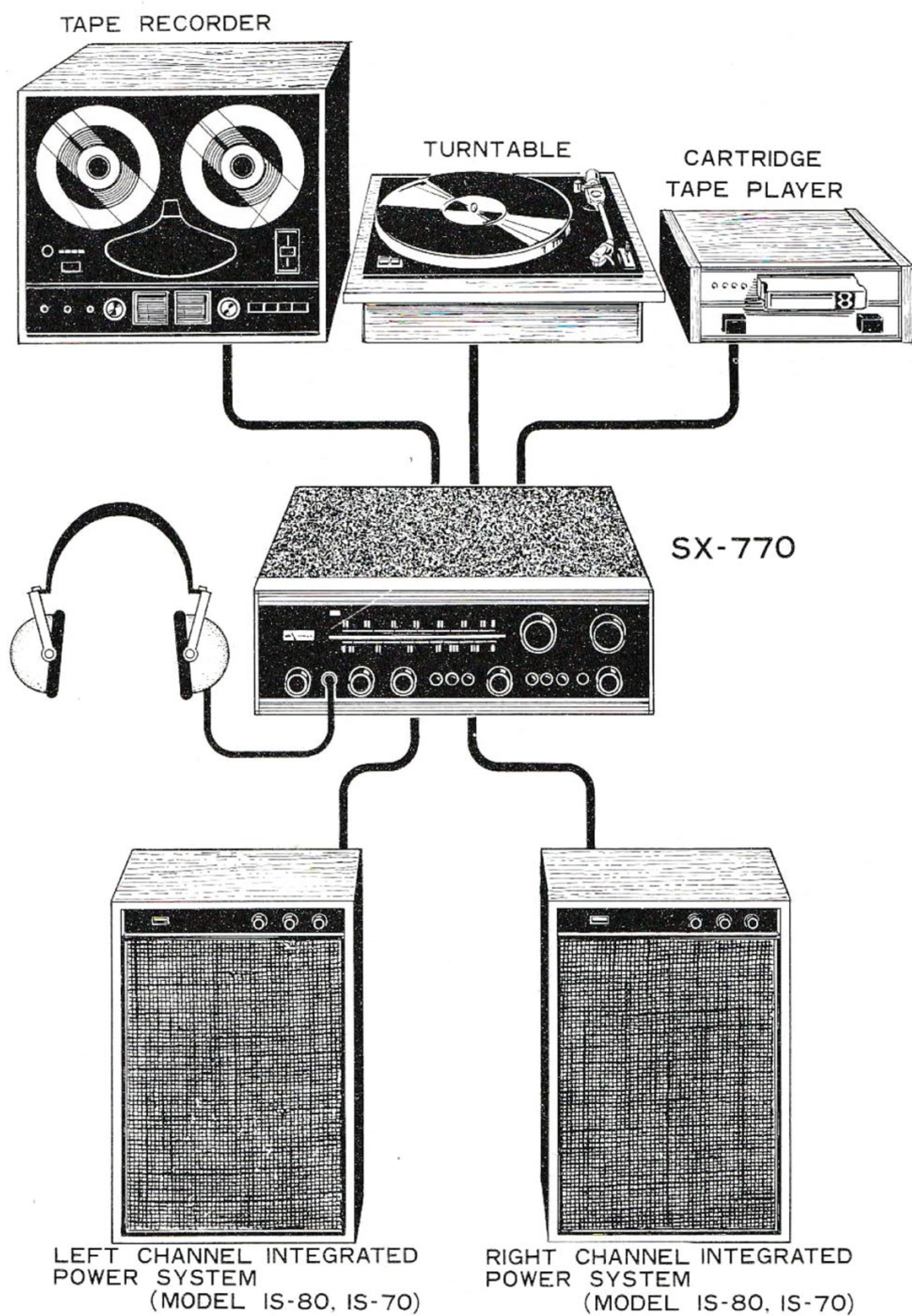

Fig. 10

### By Connecting a microphone:

The output of a microphone can be connected to the microphone jack located on the front panel. The microphone can be used simply after setting the SELECTOR Knob to the PHONO/MIC position. When the microphone is connected to the jack, however, the record player output is disconnected from Model SX-770.

#### NOTE:

1. The microphone to be used should have a high impedance.
2. Other output cannot be supplied to the loudspeaker terminals simultaneously with the microphone output.

### By using the LINE OUT terminal:

Model SX-770 can be used as an preamplifier by connecting Model IS-80 or IS-70 Power System of PIONEER's integrate stereo equipment to this terminal.

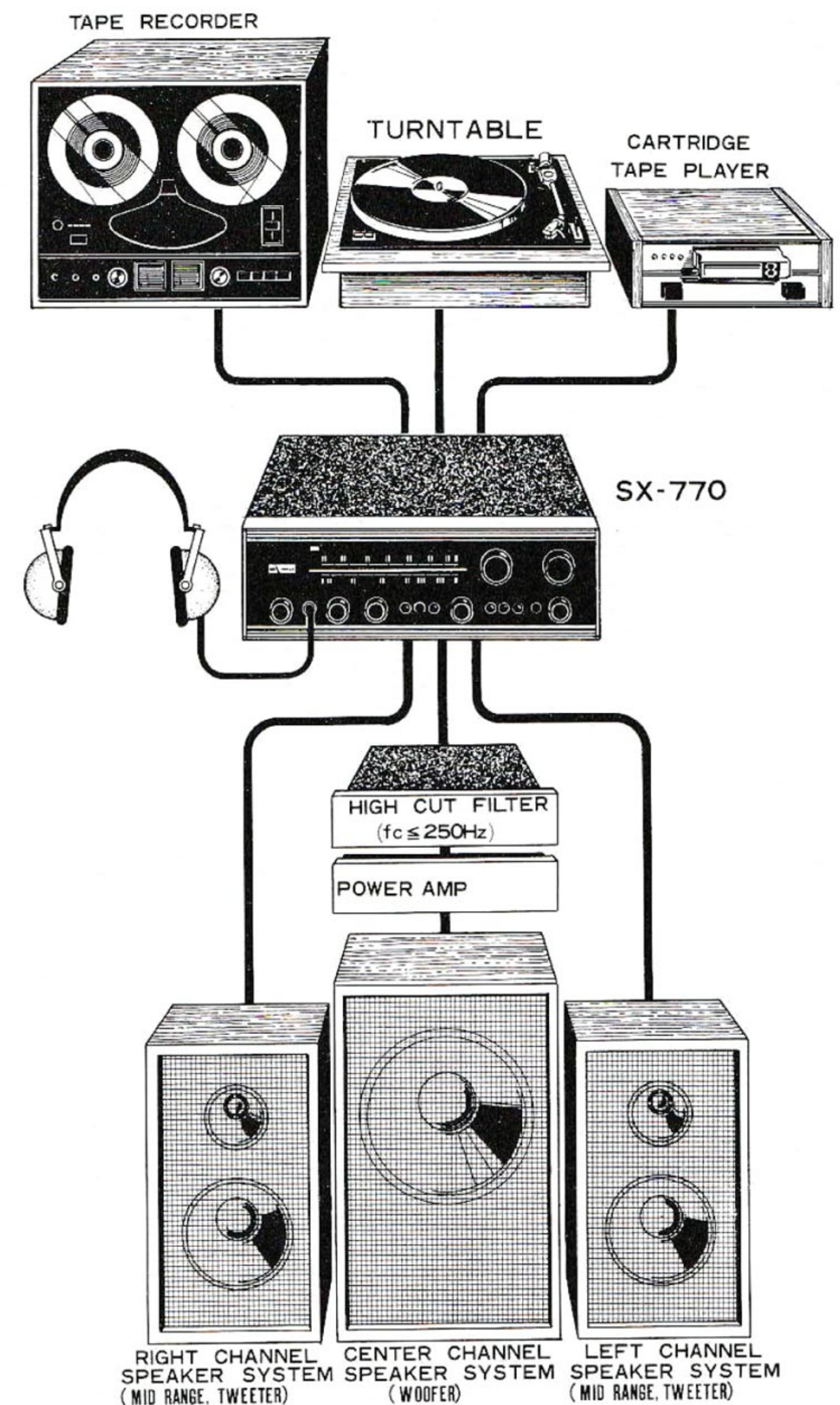

Fig. 11

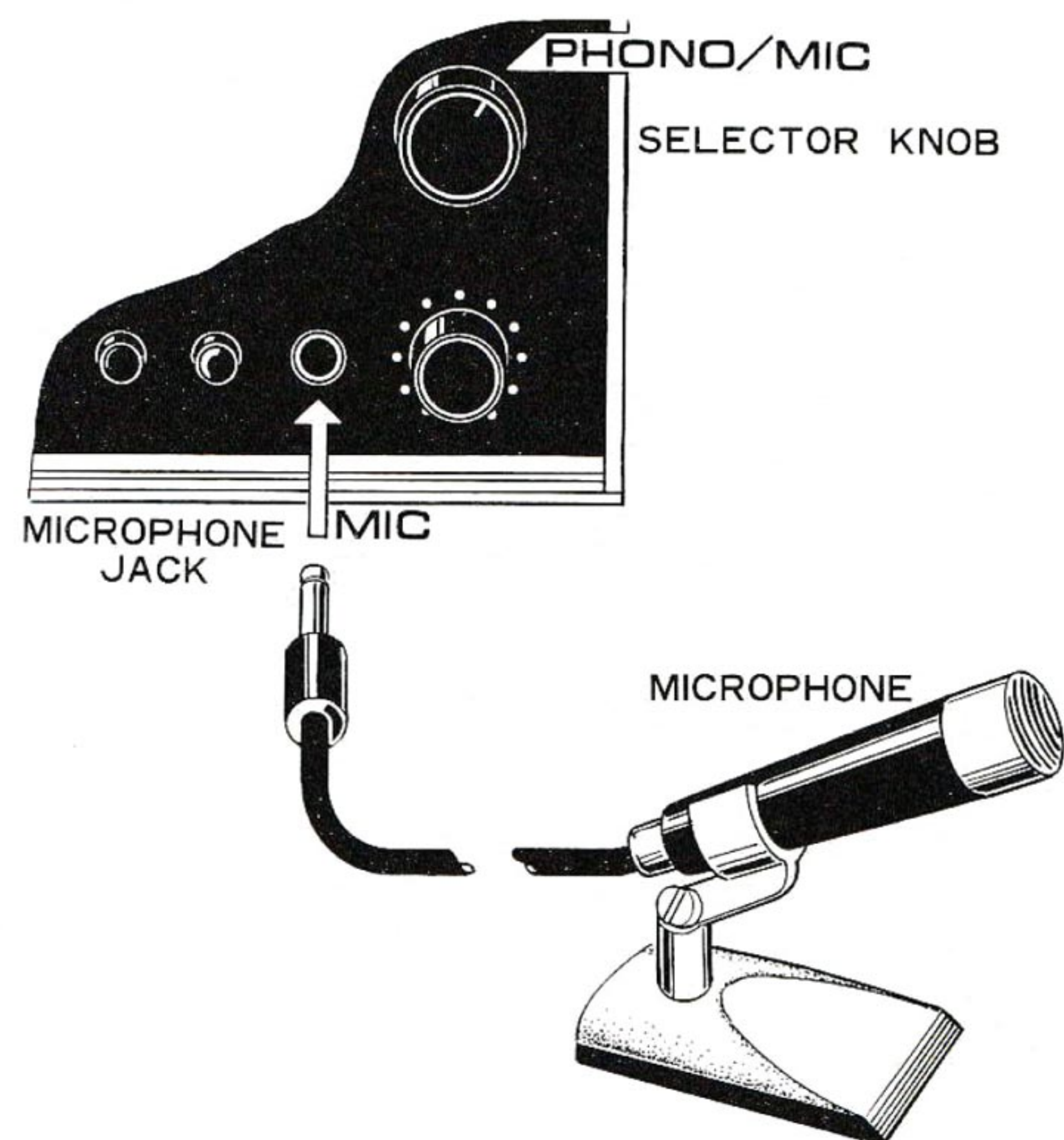

Fig. 12



# ALIGNMENT

## ALIGNMENT OF FM SECTION

Disconnect output terminal of frontend (3, 4) from (3) terminal of Tuner Unit

Position of Switch: Selector ..... FM MONO

AFC ..... OFF

Muting ..... OFF

Volume Control Setting: Fully counterclockwise

STEPS	Input			Dial Setting	Output Equipment Connections	Alignment	
	Equipment Connections	Frequency	Level			Adjust	Remarks
1	Sweep Generator	10.7MHz	40 dB		Oscilloscope	T <sub>1</sub> T <sub>2</sub> T <sub>3</sub>	Adjust for maximum sensitivity and symmetrical characteristics.
	3				12		
2	"	"	80 dB		"		Check symmetry of characteristic curve
	"				"		
3	"	"	40 dB		"	T <sub>4</sub>	Adjust the primary core of T <sub>4</sub> so that of straight portion of "S" curve will become the steepest and adjust the secondary core so that the center of "S" curve will coincide with the center of the marker.
	"				"		
4	Connect output terminal of frontend (3, 4) to (3) terminal of Tuner Unit.						
5	Signal Generator	90MHz	20 dB (400Hz 30 % )	90MHz	VTVM	L <sub>3</sub>	Adjust for maximum deflection.
	FM antenna terminal				Oscilloscope		
6	"	106MHz	"	106MHz	"	CT <sub>3</sub>	"
	"				"		
7	Repeat STEPS 5 and 6 several times.						
8	"	90MHz	"	90MHz	"	T <sub>1</sub> , T <sub>2</sub> L <sub>1</sub> , L <sub>2</sub>	"
	"				"		
9	"	106MHz	"	106MHz	"	CT <sub>1</sub> CT <sub>2</sub>	"
	"				"		
10	Repeat STEPS 8 and 9 several times						

## ALIGNMENT OF MPX SECTION

Position of Switch: SELECTOR---FM AUTO  
 AFC---OFF MUTING---OFF

Volume Control Setting: Fully Counterclockwise

Input Signal : Main (L + R) 40.5kHz Deviation (60%)  
 19kHz Pilot 7.5kHz Deviation (10%)

STEPS	Circuit to be Adjusted	Input		Connect VTVM	Alignment	
		Connections	Signal		Adjust	Remarks
1	Set the VR <sub>1</sub> (in MPX Unit) to minimum					
2	Separation	MPX SG to FM antenna terminal	L or R	A.C. VTVM 8 or 10	L <sub>1</sub>	Adjust for minimum deflection of the other channel
3	"	"	"	"	VR <sub>1</sub> L <sub>1</sub>	"
4	Repeat STEPS 2 and 3 several times					

## ALIGNMENT OF AM SECTION

Position of Switch : Selector ..... AM

Volume Control Setting: Fully Counterclockwise

STEPS	Equipment Connectors	Input		Dial Setting	Output Equipment Connections	Alignment	
		Fregacency	Level			Adjust	Remarks
1	Sweep Generator Antenna terminal through dummy	455kHz	50 dB	Point of no interference as near as 525kHz	VTVM Oscilloscope 10	T <sub>5</sub> T <sub>6</sub> T <sub>7</sub>	Adjust for maximum sensitivity and symmetrical characteristics.
2	Signal Generator Antenna terminal through dummy	600kHz	30 dB	600kHz	" "	T <sub>8</sub>	Adjust for maximum deflection
3	" "	1,400kHz	"	1,400kHz	" "	CT <sub>2</sub>	"
4	Repeat STEPS 2 and 3 several times						
5	" "	600kHz	"	600kHz	" "	L <sub>1</sub> (Adjusting core)	"
6	" "	1,400kHz	"	1,400kHz	" "	CT <sub>1</sub>	"
7	Repeat STEPS 5 and 6 several times.						



# SPECIFICATIONS

## ★ SEMICONDUCTORS

Tuner Section		Audio section	
F E T	1	Transistors	21
I C	3	Diodes , etc.	7
Transistors	9		
Diodes	12		

## ★ AUDIO SECTION

Circuitry	Single ended Push Pull
Music Power Output	4Ω 70 watts total (IHF rating) 8Ω 52 watts total (IHF rating)
RMS Rated Power Output (both channel driven)	4Ω 17 + 17 watts 8Ω 15 + 15 watts
RMS Rated Power Output (each channel driven)	8Ω 20 w/20watts
Harmonic Distortion	Less than 0.8% (at 1kHz rated output)
Frequency Response	± 3dB, from 20 Hz to 40 kHz (Over-all)
Power Bandwidth	15 Hz to 35kHz (AUX)
Damping Factor	35/8Ω (at 1kHz)
Hum & Noise (at rated output)	MAG: better than 80dB AUX: better than 95 dB
Input Impedance and Audio Sensitivity (for rated output)	MAGnetic PHONO: 2.5 mv. 50kΩ (1kHz) CERamic PHONO: 58 mv. 100kΩ MICrophone: 5mV. 100kΩ (1kHz) TAPE MONITOR: 200mv. 100 kΩ (1kHz) AUXiliary: 200mv. 100kΩ (1kHz)
Output Terminals and Jacks	Speakers: Impedance 4 to 16 ohms, Stereo headphones jack, Simultaneous tape Recording jacks, equipped with TAPE MONITOR switch. Tape recording/playback jack (DIN type)
Equalization Curves	PHONO: RIAA
Tone Controls (each channel)	BASS: boost 13dB, cut 14dB (at 50 Hz) TREBLE: boost 10 dB, cut 9dB (at 10kHz)
Filters	HIGH: cut 9dB (at 10kHz)
Loudness Contour	ON-OFF boost 12 dB at 50 Hz, Boost 7.5 dB at 10kHz, with VOLUME control set at -40 dB

## ★ FM SECTION

Circuitry	Front end using F.E.T.
Frequency Range	87.5 - 108 MHz
IHF Usable Sensitivity	1.8 μv
Image Rejection	60 dB (at 98 MHz)
Signal to Noise Ratio	70 dB (IHF rating)
Antenna Input	300 ohms (balanced)

## ★ MULTIPLEX SECTION

Circuitry	Time-switching type demodulator FM Mono Stereo Automatic selection
Channel Separation	40 dB (at 1 kHz)

## ★ AM SECTION

Circuitry	Superheterodyne
Frequency Range	525 - 1605 kHz
IHF Usable Sensitivity	10μv
Image Rejection	55 dB (at 1000 kHz)
Antenna Input	Built in Ferrite Loopstick Antenna

## ★ MISCELLANEOUS

Line Requirements	110, 117, 130, 220, 240 volts, (switchable), 50 - 60 Hz, 117VA, 108 watts (Max)
Dimensions	(overall) 16" 15/16 430 mm ..... (width) 5" 11/16 145mm (height) 13" 3/4 349mm (depth)
Weight	without package 21 lbs 2oz/9.6kg with package 24 lbs 7oz/11.1 kg

● These specifications are subject modification for improvement with out notice.

## CONDITIONS FREQUENTLY MISTAKEN FOR TROUBLES

Noise: There are a variety of noises relating to the operation of a hi-fi unit. These are generally divided into two types; (1) the unit is faulty (a transistor or part is deteriorated) and (2) an external source of noise gives noise to the unit.

When a hi-fi unit produces an unpleasant noise, it is often judged that the unit is faulty, but statistical records indicate that the majority of noises produced in hi-fi acoustic units result from external sources of noise. Due to the inherent high sensitivity

and the high fidelity in reproduction, the unit amplifies and reproduces extraneous noises, however small, into definite output noise. If your receiver produces a noise, check according to the following table and trace out the source of noise for an appropriate corrective action.

The table includes the conditions that may be mistaken for troubles of the unit.

	Symptom	Suspected Source of Noise	Diagnosis and Remedy
When Listening to Broadcasts	Continuous or intermittent noise like jjjjjj or zzzzzz.	<ul style="list-style-type: none"> <li>• Statics or listening.</li> <li>• Fluorescent lamp, motor, or thermostat may be used in house or in the vicinity of the house.</li> </ul>	In many cases, it is very difficult to remove the source of noise. In order to increase the radio input larger than the noise level, set up a good outdoor antenna and make a complete grounding.
	When a station is tuned in, hum is mixed in the program.	<ul style="list-style-type: none"> <li>• Poor fluorescent lamp, motor, or electric heater may be used in house or near the house.</li> </ul>	Reversing the line plug may occasionally alleviate this noise problem. Usually it is very difficult to eliminate the noise.
	Hissing sound noise in AM (medium wave) reception.	<ul style="list-style-type: none"> <li>• The frequency of an adjacent station is interfering with that of the station being tuned in (10kHz beat interference).</li> <li>• TV set is on in the same house with the receiver.</li> </ul>	Impossible to remove such interference. If the cause of such noise is in the TV set, increase the distance between the TV set and receiver.
	Static noise in FM reception (in particular, when automobiles run close to the house).	<ul style="list-style-type: none"> <li>• White noises generated from automobile engines.</li> <li>• Radio frequency sewing machine or welding machine being used near your house.</li> </ul>	In an area surrounded by hills or high buildings, the FM input signals are very weak. Thus the noise limiter in the circuit loses its function. Set up an outdoor FM antenna having many reflector elements.
When Playing Records	Reception of FM stereo program contains more noise than FM mono program.	<ul style="list-style-type: none"> <li>• Note that the service area covered by an FM stereo broadcast is about 50 % of that of a regular mono broadcast.</li> </ul>	Increasing FM input signal may alleviate this problem. Use an exclusive FM outdoor antenna instead of the indoor T-antenna.
	Hum or buzz. When switched to radio reception, the noise will disappear.	<ul style="list-style-type: none"> <li>• Poor connection of shielded wire (a).</li> <li>• Jack connection is loose. (b)</li> <li>• Line cord or fluorescent lamp is near the shielded wire. (c)</li> <li>• Poor grounding. (d)</li> <li>• HAM transmitting station or TV transmitting station is near your house. (e)</li> </ul>	Correct the conditions stated in (a), (b), (c) or (d). In case of (e), report it to an official activity.
	Output tone quality is poor and mixed with noise. Treble is not clear.	<ul style="list-style-type: none"> <li>• Stylus is worn out. (a)</li> <li>• Record is worn out. (b)</li> <li>• Dust adheres to stylus. (c)</li> <li>• Improper mounting of stylus. (d)</li> <li>• Stylus pressure is not proper. (e)</li> <li>• The TREBLE sound level is too high.</li> </ul>	Check (a) through (e) and correct the condition.  Lower the TREBLE level.

Further, watch the following conditions: These are also apt to be mistaken for troubles of the unit.

	Symptom	Suspected Source of Noise	Diagnosis and Remedy
	Power is not turned on although the power switch is set to ON.	<ul style="list-style-type: none"> <li>• Fuse is blown. (a)</li> <li>• Line plug is loose. (b)</li> </ul>	Check (a) and (b) and correct the condition.
	In playing a record, increasing the volume will cause howling.	<ul style="list-style-type: none"> <li>• Distance between the record player and the speakers is too short.</li> <li>• The place on which the record player or speakers are set is unstable.</li> </ul>	Change the distance or rearrange the installation positions of the unit and speakers. (Installing the record player on a firm, solid stand may alleviate this problem.) Do not enhance the BASS sound level excessively.



## PARTS LIST

### CAPACITORS

IN  $\mu\text{F}$ , 10% TOLERANCE UNLESS OTHERWISE NOTED P:  $\mu\mu\text{F}$

Symbol	Description			Part No.
C1	Ceramic	47p		50V
C2	"	"		"
C9	Mylar	0.003		"
C10	Ceramic	220p		"
C11	"	"		"
C12	Electrolytic	220		3V
C15	"	3000		50V
C16	Oil paper	0.01		C15-001-0
C17	Ceramic	"	+ 80%	DC.1.4KV C43-003-0
C18	"	"	- 20%	"
C19	Mylar	0.0018		50V
C20	"	"		"

### RESISTORS

IN  $\Omega$ , 10% TOLERANCE, 1/4 WATT UNLESS OTHERWISE NOTED K:  $\text{K}\Omega$ , M:  $\text{M}\Omega$ , W: WAT

Symbol	Description			Part No.
R1	Carbon film	1M		
R2	"	"		
R3	"	100K		
R4	"	"		
R5	"	68K		
R6	"	"		
R7				
R8	Compound part for REC terminal			W52-004-0
R9				
R10				
R11	Carbon film	33K		
R12	"	"		
R15	"	3.9K	$\frac{1}{2}\text{W}$	
R16	"	"	"	
R17	"	1K	"	
R18	"	"	"	
R19	"	39K	"	
R20	"	"	"	
R21	"	150	3W	
R22	"	"	"	
R23	"	1K	$\frac{1}{2}\text{W}$	
R24	"	1M		

### COILS AND TRANSFORMERS

Symbol	Description	Part No.
L1	AM Ferrite Loopstick Antenna	T42-025-0
L2	Choke Coil	T24-030-0
T1	POWER Transformer	T52-161-0
T2	Matching Transformer	T61-041-B
T3	"	"

### SWITCHES

Symbol	Description	Part No.
S1	Input Selector	S13-030-0
S2	Output Selector	S11-022-A

### POTENTIOMETERS

Symbol	Description	Part No.
VR1	250k $\Omega$ dual, Volume	C82-038-0
VR2	50k $\Omega$ dual, Balance	C85-052-0

### MISCELLANEOUS

Symbol	Description	Part No.
	FM FRONT END	W11-035-0
	TUNER Unit	W35-012-C
	MPX Unit	W13-024-D
	HEAD AMP Unit	W15-032-B
	CONTROL AMP Unit	W15-033-0
	MAIN AMP Unit	W15-085-0
	PUSH SWITCH Unit (A)	W15-086-0
	PUSH SWITCH Unit (B)	W15-087-0
	POWER SUPPLY Unit	W16-024-0
	MUTING Unit	W18-026-0
	Front Panel	M21-303-0
	Plastics Panel	M21-309-A
	Wooden Case	M52-112-0
	Dial Pulley	M49-009-B
	Dial Pulley (for Tuning Capacitor)	M42-041-C
	Dial Glass	A 33-087-0
	Dial Pointer	A 31-087-A
	Knob, Selector	A 12-136-A
	Knob, Tuning	A 12-139-A
	Knob, Volume, Balance, Bass, Treble, Output Selector	A 12-131-A
	Tuning Meter	A 91-009-A
	Pilot Lamp (for Dial Glass)	E 22-017-0
	Pilot Lamp (for Tuning Meter)	E 22-020-0
	Pilot Lamp (for FM Stereo)	E 22-015-A
	Pilot Lamp Socket	K42-003-0
	Bracket for FM Stereo	A62-045-0
	Fuse 1A	E21-004-0
	Fuse 2A	E21-005-0
	Line Voltage Selector	S11-018-0
	Microphone Jack	K72-020-0
	Headphone Jack	K72-021-B
	Connector 5P	K93-003-B
	Jack for Speaker	K73-003-A
	Spare A.C Outlet	K82-012-0
	Terminal 6p	K22-013-C
	Terminal 4p	K22-010-A
	Terminal 2p	K21-009-C
	Terminal 1p	K21-005-C



## FM FRONTEND (W11-035)

### CAPACITORS

Symbol	Description				Part No.
C1	Ceramic	15p		50V	
C2	"	100p		"	
C3	"	3p	±0.25p	"	
C4	"	0.02	+80% -20%	"	
C5	"	"	"	"	
C6	"	18p	±5%	"	
C7	"	2p	±0.25p	"	
C8	"	10p	±1p	"	
C9	"	0.001	±20%	"	
C10	"	0.02	+80% -20%	"	
C11	"	100p		"	
C12	"	0.02	+80% -20%	"	
C13	"	"	"	"	
C14	"	6p	±0.5p	"	
C15	"	1p	±0.25p	"	
C16	"	10p	±1p	"	
C17	"	5p	±0.5p	"	
C18	"	15p		"	
C19	"	10p	±1p	"	
C20	"	0.02	+80% -20%	"	
C21	"	0.001	±20%	"	

### RESISTORS

Symbol	Description				Part No.
R1	Carbon film	100K			
R2	"	1M			
R4	"	47			
R5	"	4.7K			
R6	"	15K			
R7	"	1K			
R8	"	1M			
R9	"	10K			
R10	"	3.3K			
R11	"	10K			
R12	"	100			
R13	"	150K			

### DIODE AND TRANSISTORS

Symbol	Description	Part No.
D1	1S351R Vari-Cap. Diode	
Q1	2SK-19 FET	
Q2	SE3001 Transistor	
Q3	"	

### COILS AND TRANSFORMER

Symbol	Description	Part No.
L1	R.F Coil	
L2	R.F Choke Coil	
L3	OSC. Coil	
L4	RF Coil	
T1	ANT Coil	
T2	IF Transformer	

## MUTING UNIT (W18-026)

### CAPACITORS

Symbol	Description				Part No.
C1	Electrolytic	.47		16V	
C2	"	2.2		35V	
C3	Mylar	0.0056	±20%	50V	

### RESISTORS

Symbol	Description				Part No.
R1	Carbon film	33K			
R2	"	33K			
R3	"	330			
R4	"	10K			
R5	"	1.8K			
R6	"	10K			
R7	"	68K			
R8	"	39K			
R9	"	4.7K			
R10	"	2.7K			
R11	"	22K			

### TRANSISTORS

Symbol	Description	Part No.
Q1	2SC870	
Q2	"	
Q3	"	

### POTENTIOMETER

Symbol	Description	Part No.
VR1	2KΩ Semi fixed, Muting level control	C92-057-0

## MPX UNIT (W13-024)

### CAPACITORS

Symbol	Description				Part No.
C1	Styrol	2200p		50V	C15-007-0
C2	Electrolytic	1		"	
C3	Mylar	0.047	±20%	"	
C4	Styrol	0.01		"	C15-005-0
C5	"	"		"	
C6	Electrolytic	2.2		35V	
C7	Styrol	3300p		50V	C15-006-0
C8	Mylar	2200p		"	
C9	"	"		"	
C10	Electrolytic	22		25V	
C11	Styrol	1500p		50V	
C12	"	"		"	
C13	Electrolytic	0.47		"	
C14	"	"		"	

### RESISTORS

Symbol	Description				Part No.
R1	Carbon film	15K			
R2	"	"			
R3	"	12K			
R4	"	2.2K			
R5	"	4.7K			
R6	"	3.3K			
R7	"	10K			
R8	"	"			

### INTEGRATED CIRCUIT

Symbol	Description	Part No.
Q1	MPX IC	MC1304L

### COILS AND TRANSFORMERS

Symbol	Description	Part No.
L1	19kHz Coil	T75-018-A
L2	"	"
L3	38kHz Coil	T75-019-A
LPF1	38kHz Filter	T75-015-0
LPF2	"	"

### POTENTIOMETER

Symbol	Description	Part No.
VR1	4.7K, Semi-fixed	C92-051-0

## TUNER UNIT (W35-012)

### CAPACITORS

Symbol	Description				Part No.
C1	Ceramic	0.01	+100% 0	25V	
C2	"	"	"	"	
C3	"	5p	±0.5p	50V	
C4	"	0.01	+100% 0	25V	
C5	"	"	"	"	
C6	"	0.04	"	"	
C7	"	"	"	"	
C8	Electrolytic	10		10V	
C9	Ceramic	0.04	+100% 0	25V	
C10	"	"	"	"	
C11	"	"	"	"	
C12	Mylar	0.01		50V	
C13	Styrol	450p		"	
C14	Ceramic	0.04	+100% 0	25V	
C15	"	27p		50V	
C16	"	12p		"	
C17	"	560p		"	
C18	"	0.04	+100% 0	25V	
C19	Electrolytic	4.7		16V	
C20	Ceramic	0.04	+100% 0	25V	
C21	"	"	"	"	
C22	"	3p	±0.25p	50V	
C23	"	68p		"	
C24	"	0.01	+100% 0	25V	
C25	Mylar	0.1		50V	
C26	Ceramic	0.01	+100% 0	25V	
C27	"	"	"	"	
C28	Mylar	4700p		50V	
C29	"	2200p		"	
C30	Electrolytic	0.47		"	
C31	Ceramic	180p		"	
C32	Electrolytic	4.7		16V	
C33	"	1		25V	
C34	Ceramic	0.04	+100% 0	"	
C35	Electrolytic	100		25V	
C36	Ceramic	1p	±0.1p	50V	
C37	"	0.01	+100% 0	25V	
C38	"	0.04	"	"	
C39	"	100p		50V	
C4	"	0.04	+100% 0	25V	



## RESISTORS

Symbol	Description			Part No.
R1	Carbon film	56K		
R2	"	100		
R3	"	8.2K		
R4	"	1.8K		
R5	"	470		
R6	"	"		
R7	"	4.7K		
R8	"	15K		
R9	"	2.2K		
R10	"	470		
R11	"	1.5K		
R12	"	"		
R13	"	22K		
R14	"	470		
R15	"	680		
R16	"	2.7K		
R17	"	39K		
R18	"	33K		
R19	"	100		
R20	"	5.6K		
R21	"	2.7K		
R22	"	4.7K		
R23	"	100		
R24	"	220K		
R25	"	"		
R26	"	22K		
R27	"	10K		
R28	"	47		
R29	"	820		
R30	"	22		
R31	"	100K		
R32	"	100		

## DIODES AND TRANSISTORS

Symbol	Description	Part No.
D1	IS188 Diode	
D2	"	
D3	"	
D4	"	
D5	"	
D6	"	
D7	"	
D8	"	
D9	"	
D10	"	
D11	"	
Q1	2SC460-A Transistor	
Q2	2SC461-A Transistor	
Q3	2SC460-A Transistor	
Q4	"	
Q5	μA703E I.C	
Q6	"	

## COIL AND TRANSFORMERS

Symbol	Description	Part No.
T1	FM IF Transformer	T73-030-0
T2	"	T73-031-0
T3	"	T73-032-0
T4	"	T74-009-0

T5	AM IF Transformer	T71-026-0
T6	"	"
T7	"	T72-019-0
T8	MW OSC Coil	T43-009-A

## HEAD AMP UNIT (W15-032)

### CAPACITORS

Symbol	Description			Part No.
C1	Electrolytic	10		10V
C2	"	"		"
C3	Ceramic	30p		50V
C4	"	"		"
C5	"	100p		"
C6	"	"		"
C7	Electrolytic	0.47		"
C8	"	"		"
C9	"	33		6V
C10	"	"		"
C11	Mylar	0.01	± 20%	50V
C12	"	"	"	"
C13	"	0.003	"	"
C14	"	"	"	"
C15	Electrolytic	100		35V
C16	"	"		"

## RESISTORS

Symbol	Description			Part No.
R1	Carbon film	1K		
R2	"	"		
R3	"	150K		
R4	"	"		
R5	"	180K		
R6	"	"		
R7	"	120K		
R8	"	"		
R9	"	390		
R10	"	"		
R11	"	470K		
R12	"	"		
R13	"	15K		
R14	"	"		
R15	"	2.7K		
R16	"	"		
R17	"	330K		
R18	"	"		
R19	"	27K		
R20	"	"		
R21	"	56K		
R22	"	"		
R23	"	2.2K		
R24	"	"		

## TRANSISTORS

Symbol	Description	Part No.
Q1	2SC871 Transistor	
Q2	"	
Q3	2SC870 Transistor	
Q4	"	

## CONTROL AMP UNIT (W15-033)

### CAPACITORS

Symbol	Description				Part No.
C1	Electrolytic	0.47		50V	
C2	"	"		"	
C3	Ceramic	10p		"	
C4	"	"		"	
C5	Electrolytic	100		3V	
C6	"	"		"	
C7	"	2.2		35V	
C8	"	"		"	
C9	Mylar	0.003	±20%	50V	
C10	"	"	"	"	
C11	"	0.01	"	"	
C12	"	"	"	"	
C13	"	"	"	"	
C14	"	"	"	"	
C15	"	0.1	"	"	
C16	"	"	"	"	
C17	Electrolytic	47		35V	
C18	"	"		"	

### RESISTORS

Symbol	Description				Part No.
R1	Carbon film	470K			
R2	"	"			
R3	"	220K			
R4	"	"			
R5	"	22K			
R6	"	"			
R7	"	68K			
R8	"	"			
R9	"	8.2K			
R10	"	"			
R11	"	1K			
R12	"	"			
R13	"	100K			
R14	"	"			
R15	"	10K			
R16	"	"			
R17	"	2.7K			
R18	"	"			
R19	"	4.7K			
R20	"	"			
R21	"	1.5K			
R22	"	"			

### TRANSISTORS

Symbol	Description	Part No.
Q1	2SC870 Transistor	
Q2	"	

### POTENTIOMETERS

Symbol	Description	Part No.
VR1	100kΩ dual, TREBLE Control	C82-040-0
VR2	100kΩ dual, BASS Control	"

## MAIN AMP UNIT (W15-085)

### CAPACITORS

Symbol	Description				Part No.
C1	Electrolytic	100		25V	
C2	"	"		"	
C3	"	10		10V	
C4	"	"		"	
C5	"	22		25V	
C6	"	"		"	
C7	"	47		3V	
C8	"	"		"	
C9	Ceramic	150p		50V	
C10	"	"		"	
C11	Electrolytic	47		3V	
C12	"	"		"	
C13	"	100		25V	
C14	"	"		"	
C15	Mylar	0.05	±20%	50V	
C16	"	"	"	"	
C17	Electrolytic	1000		25V	
C18	"	"		"	
C19	Ceramic	100p		50V	
C20	"	"		"	
C21	"	30p		50V	
C22	"	"		"	
C23	"	220p		"	
C24	"	"		"	

### RESISTORS

Symbol	Description				Part No.
R1	Carbon film	150K			
R2	"	"			
R3	"	8.2K			
R4	"	"			
R5	"	220K			
R6	"	"			
R7	"	22K			
R8	"	"			
R9	"	4.7K			
R10	"	"			
R11	"	470			
R12	"	"			
R13	"	150			
R14	"	"			
R15	"	82K			
R16	"	"			
R17	"	6.8K			
R18	"	"			
R19	"	150			
R20	"	"			
R21	"	1K			
R22	"	"			
R23	"	3.3K			
R24	"	"			
R25	"	220			
R26	"	"			
R27	"	22			
R28	"	"			
R29	"	220			
R30	"	"			



R31	Wire wound	0.5		2W
R32	"	"		"
R33	"	"		"
R34	"	"		"
R35		68		
R36		"		
R37		27K		
R38		"		
R39		33K		
R40		"		
R41	Carbon film	470		
R42	"	"		

### VARISTORS AND TRANSISTORS

Symbol	Description	Part NO.
D1	STV-3 Varistor	
D2	"	
Q1	2SC870 Transistor	
Q2	"	
Q3	2SC734-Y Transistor	
Q4	"	
Q5	2SC904 Transistor	
Q6	"	
Q7	2SA569 Transistor	
Q8	"	
Q9	2SD91 Transistor	
Q10	"	
Q11	"	
Q12	"	

### POTENTIOMETERS

Symbol	Description	Part No.
VR1	50kΩ Semi fixed, Bias Control	C92-044-0
VR2	"	"
VR3	50Ω Semi fixed, Bias Control	C92-043-0
VR4	"	"

### PUSH SWITCH UNIT A (W15-086)

#### CAPACITORS

Symbol	Description				Part No.
C3	Ceramic	220p		50V	
C4	"	"		"	
C5	Mylar	0.03		"	
C6	"	"		"	

#### RESISTORS

Symbol	Description				Part No.
R13	Carbon film	12K			
R14	"	"			

#### SWITCHES

Symbol	Description	Part No.
S3	TAPE Monitor Switch (Push type)	S31-022-0
S4	Mode Switch ( " )	"
S5	Loudness Switch ( " )	"

### PUSH SWITCH UNIT B (W15-087)

#### CAPACITORS

Symbol	Description				Part No.
C7	Mylar	0.01		50V	
C8	"	"		"	
C13	Electrolytic	0.47		25V	

#### RESISTOR

Symbol	Description				Part No.
R26	Carbon film	220K			

#### SWITCHES

Symbol	Description	Part No.
S6	High Cut Filter Switch (Push type)	S31-022-0
S7	AFC Switch ( " )	"
S8	Muting Switch ( " )	"

### POWER SUPPLY UNIT (W16-024)

#### CAPACITORS

Symbol	Description				Part No.
C1	Ceramic	0.01		500V	
C2	"	"		"	
C3	"	100p		50V	
C4	Electrolytic	100		"	
C5	"	220		25V	
C6	"	"		"	
C7	"	100		16V	
C8	Ceramic	0.01		50V	

#### RESISTORS

Symbol	Description				Part No.
R1	Carbon film	3.3K			
R2	"	22		1/2W	
R3	"	33K			
R4	"	39K			
R5	"	2.7K			
R6	"	560		1/2W	
R7	"	22		"	
R8	"	"		"	

#### DIODES AND TRANSISTORS

Symbol	Description	Part No.
D1	SW-1-02 Diode	
D2	"	
D3	SD-1Z Diode	
D4	"	
D5	1S338Q zener diode	
Q1	2SC497 Transistor	
Q2	2SC870 Transistor	
Q3	2SC497 Transistor	

## PRINTED CIRCUIT BOARD

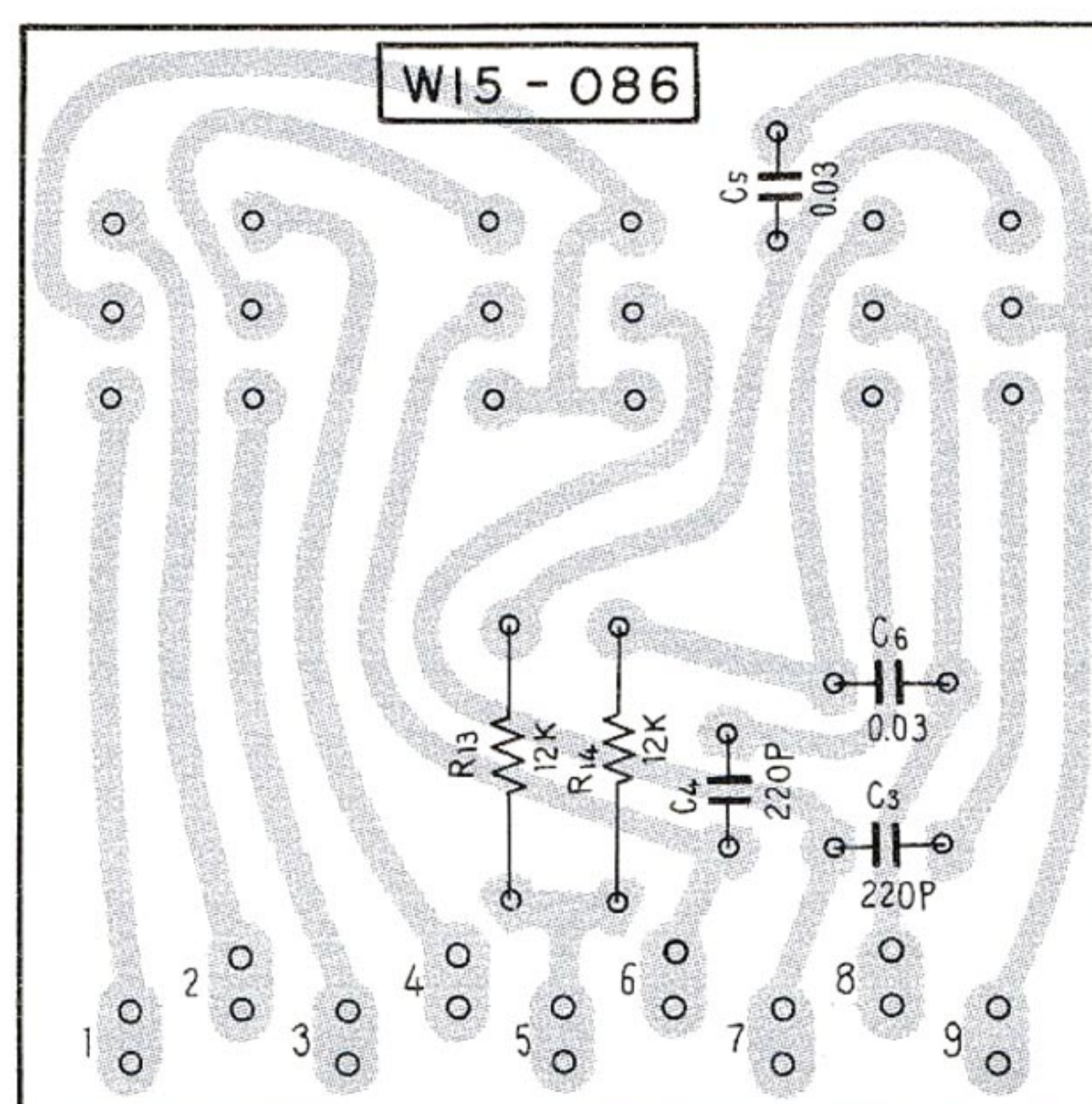
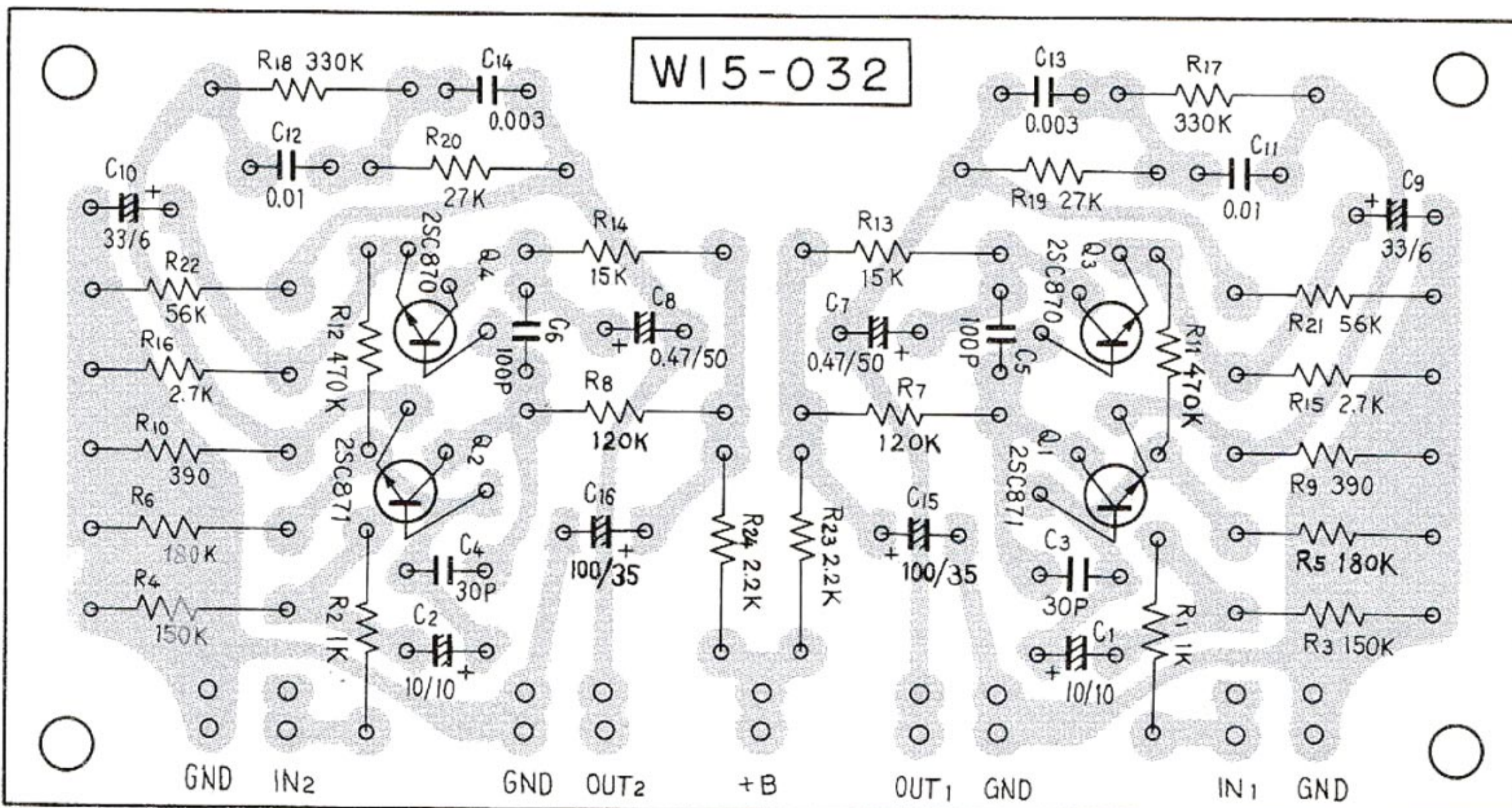
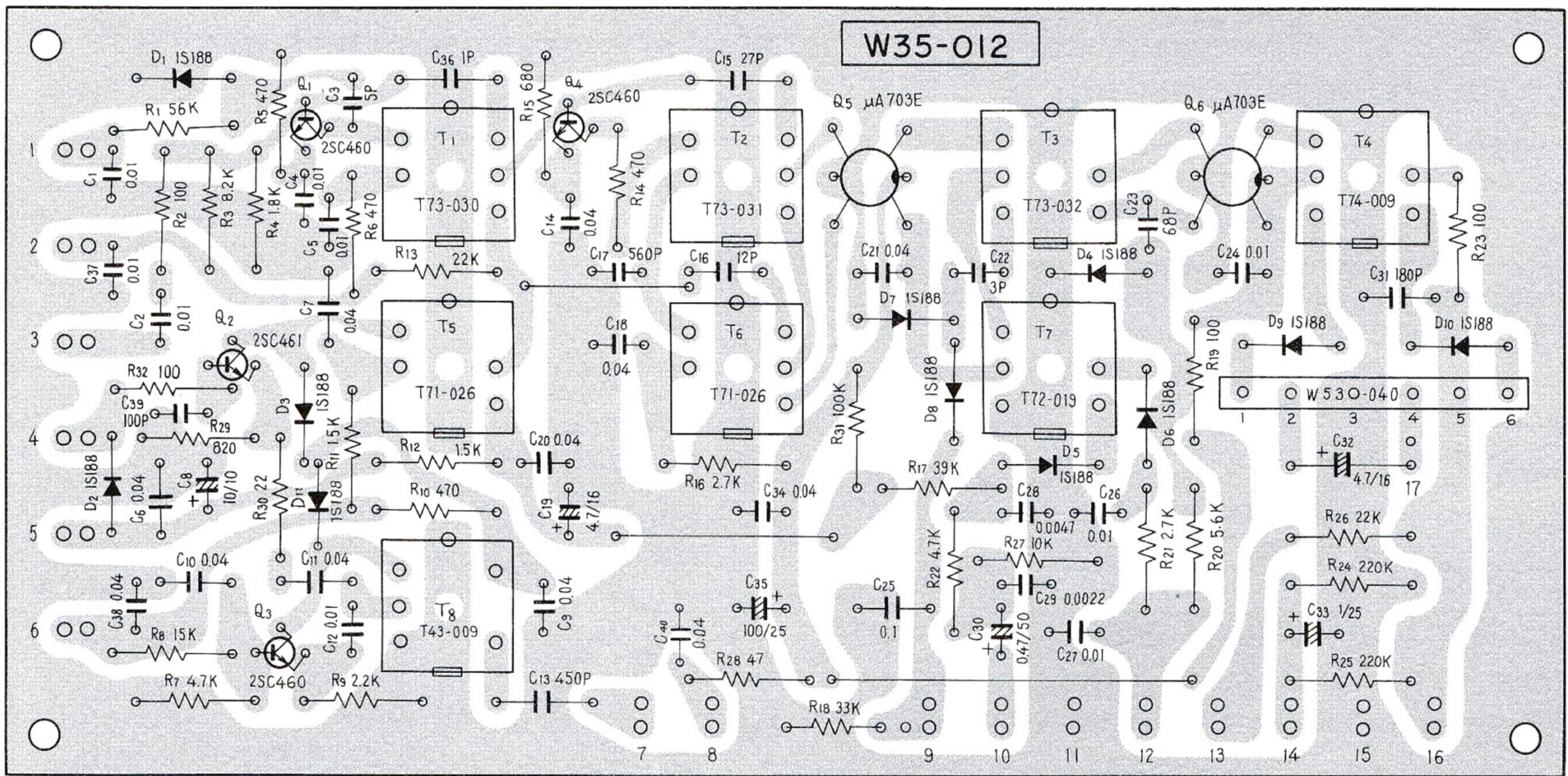
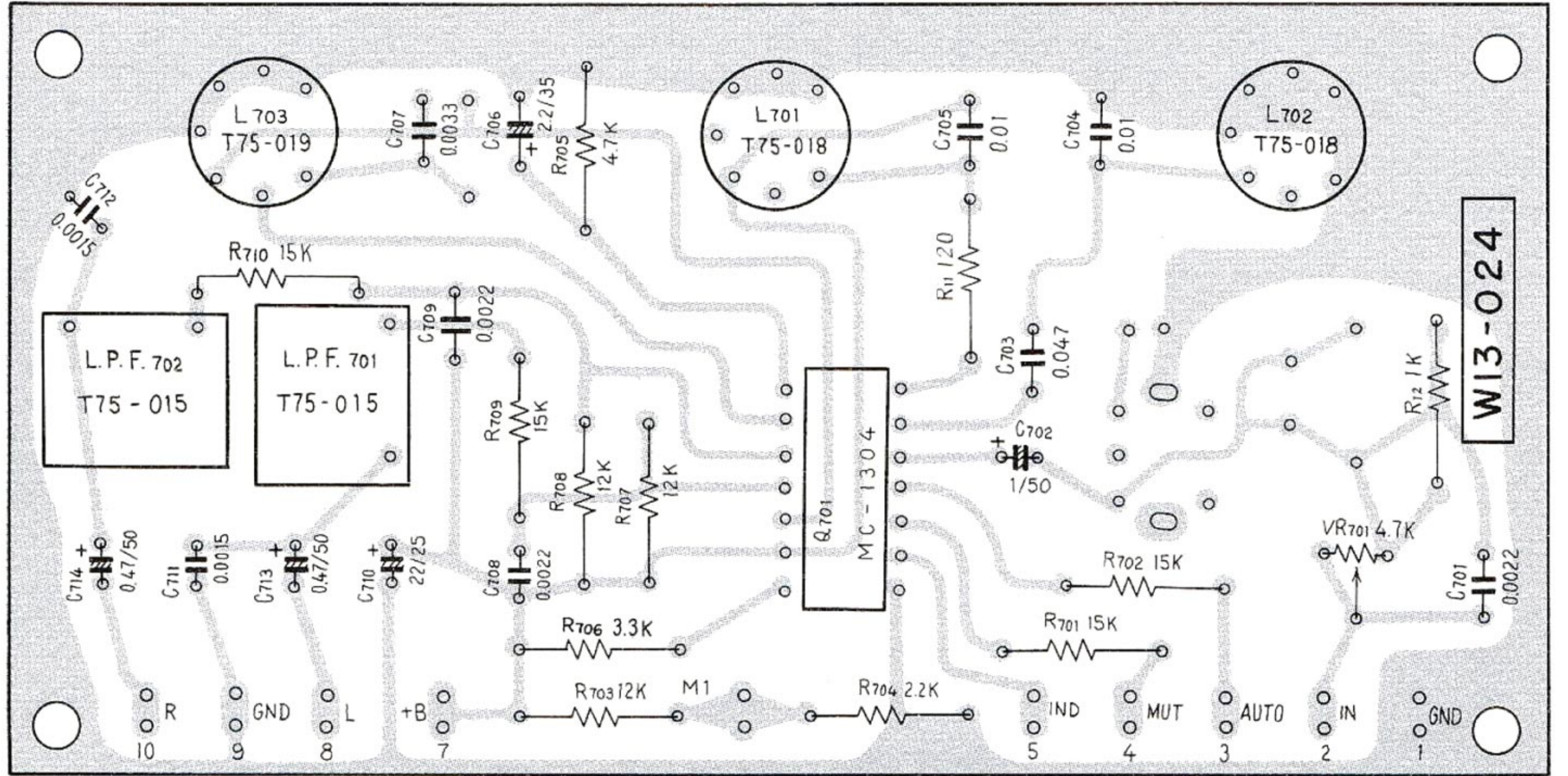
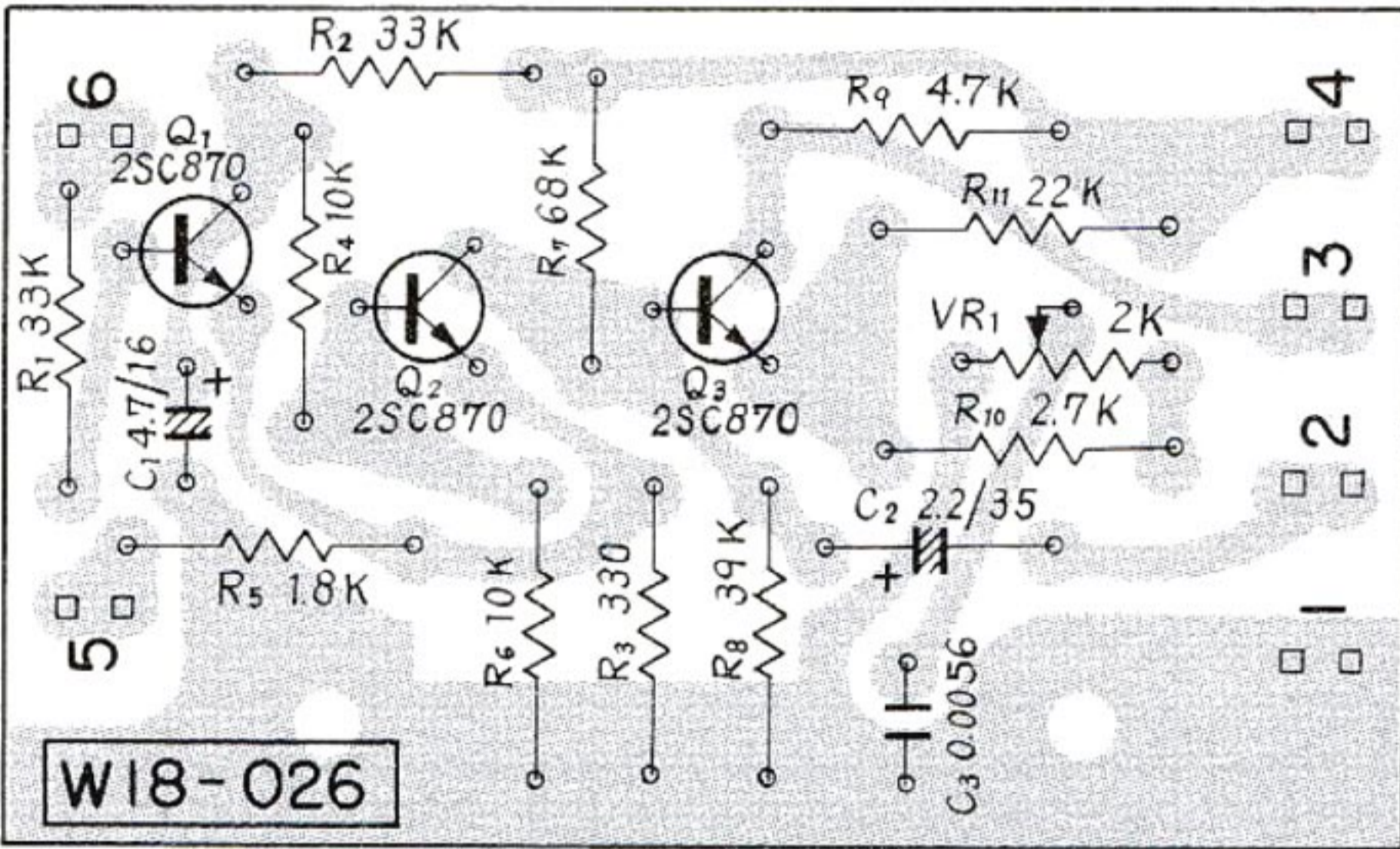

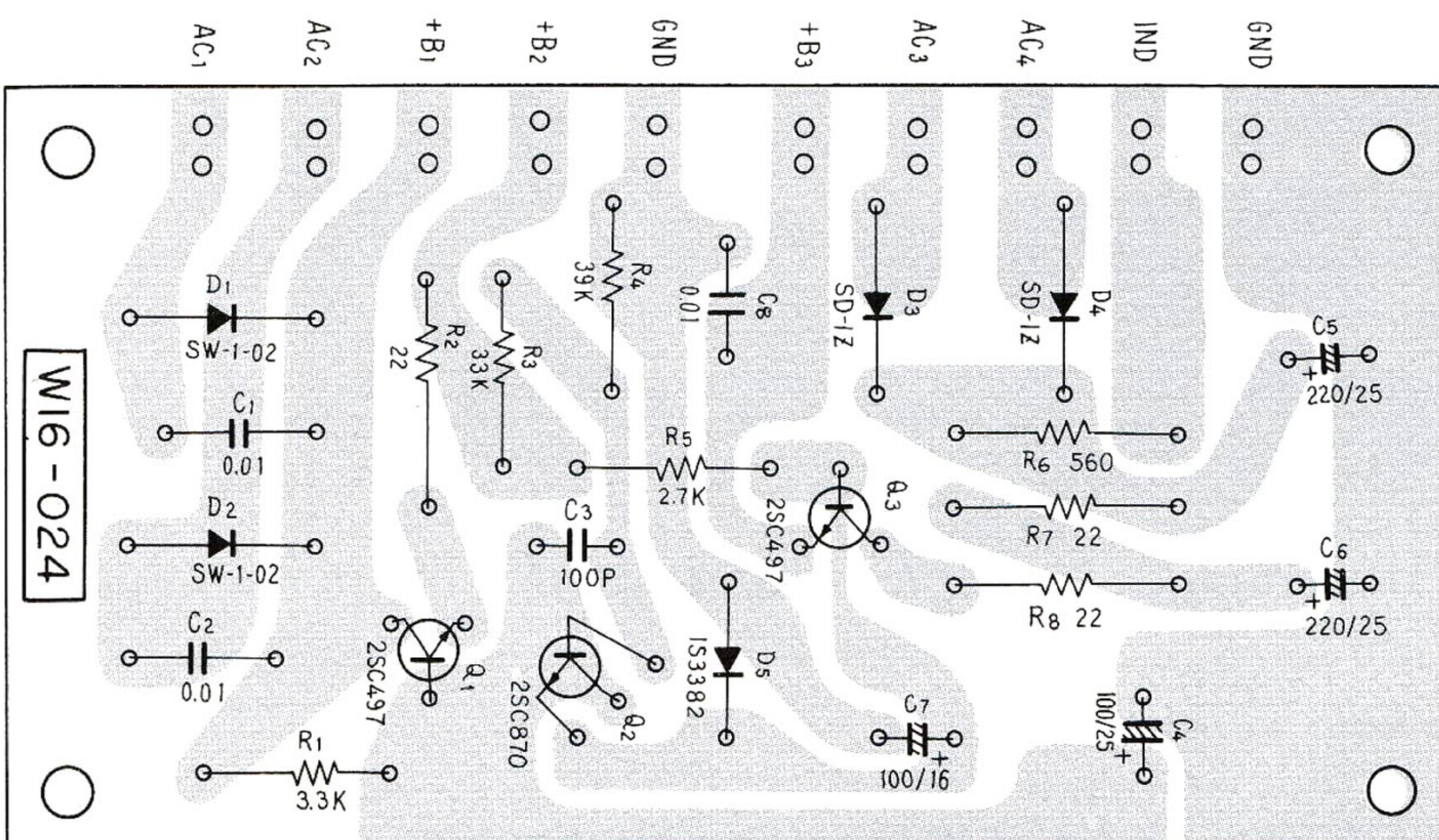
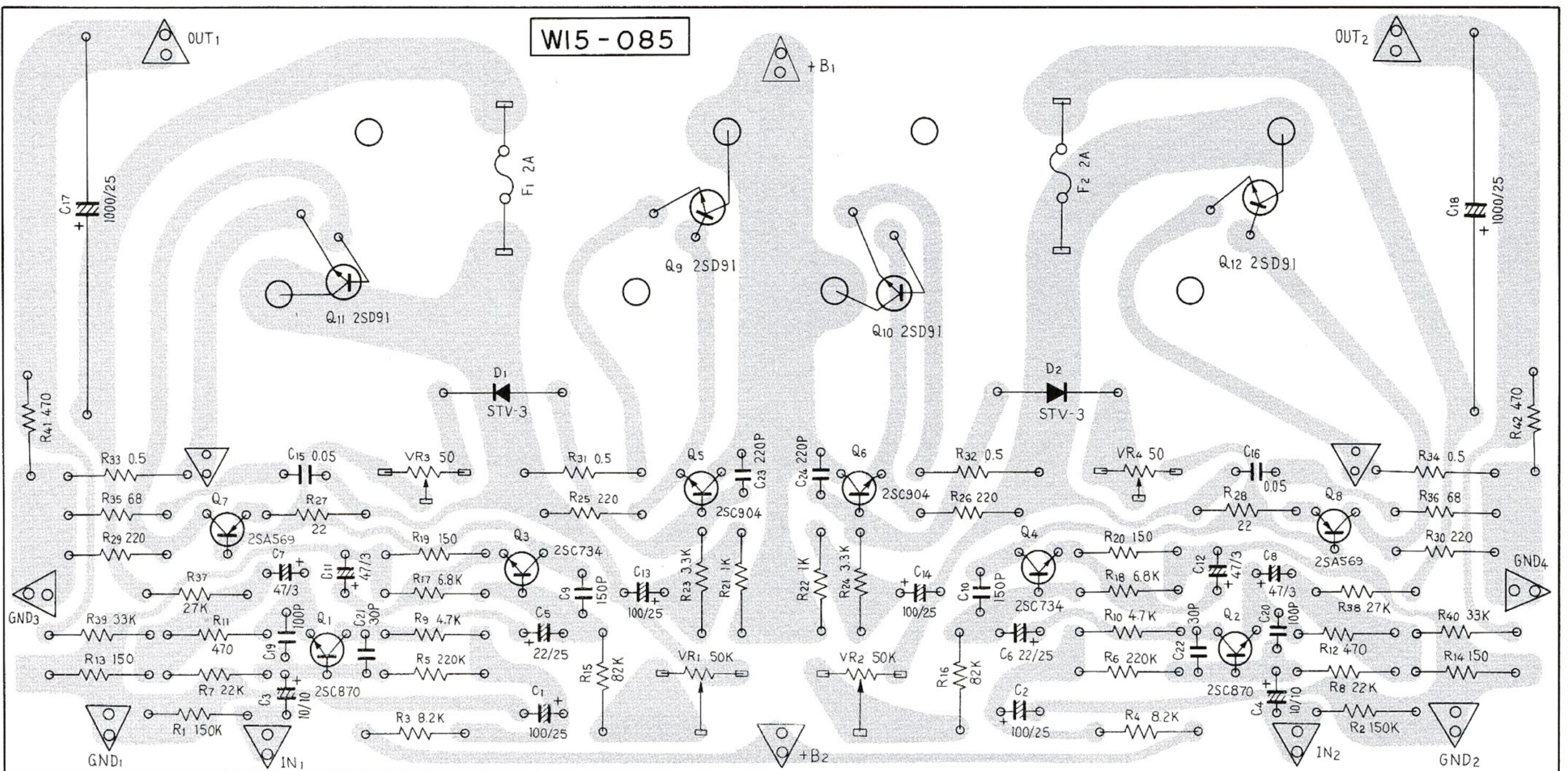
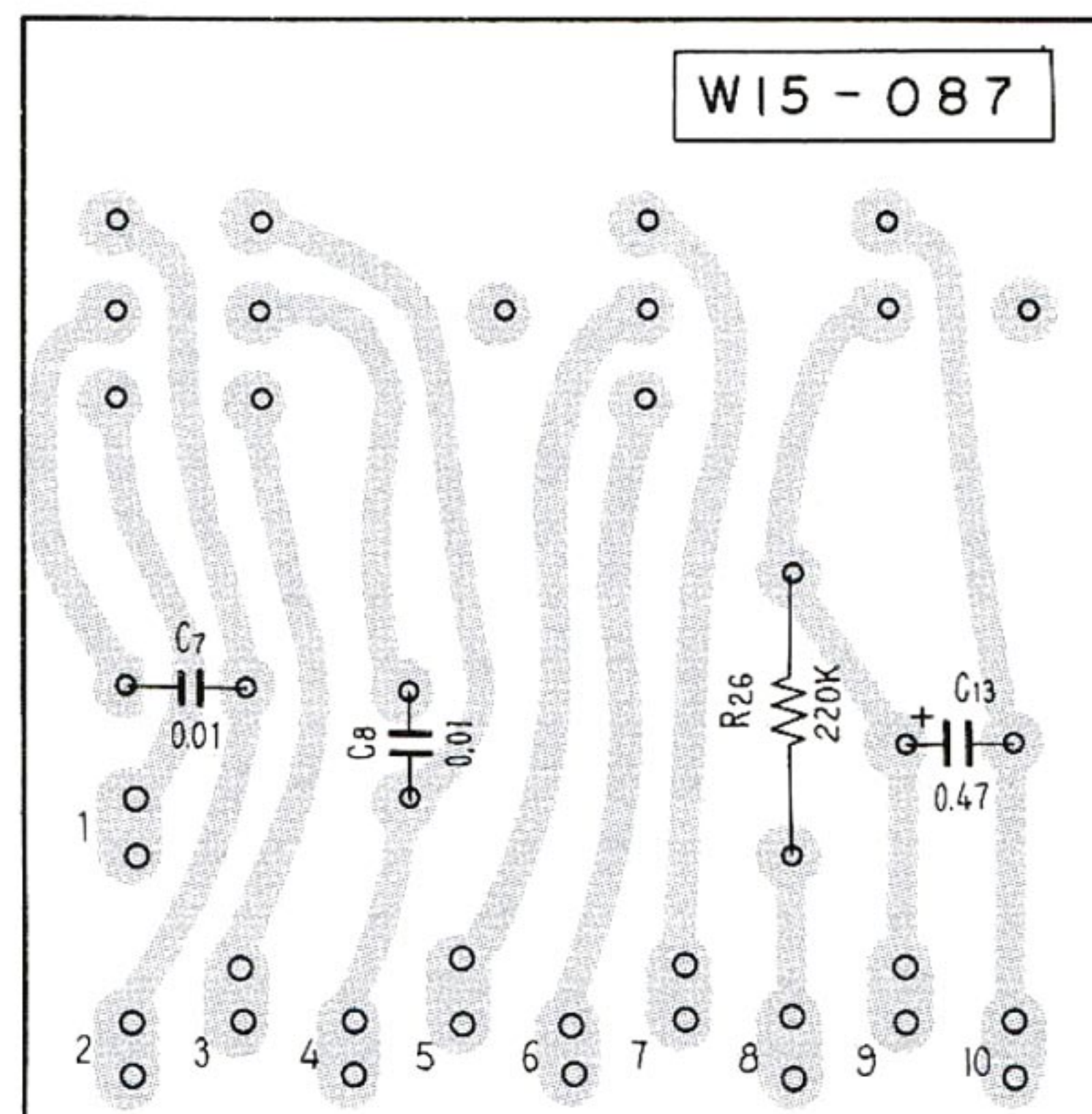
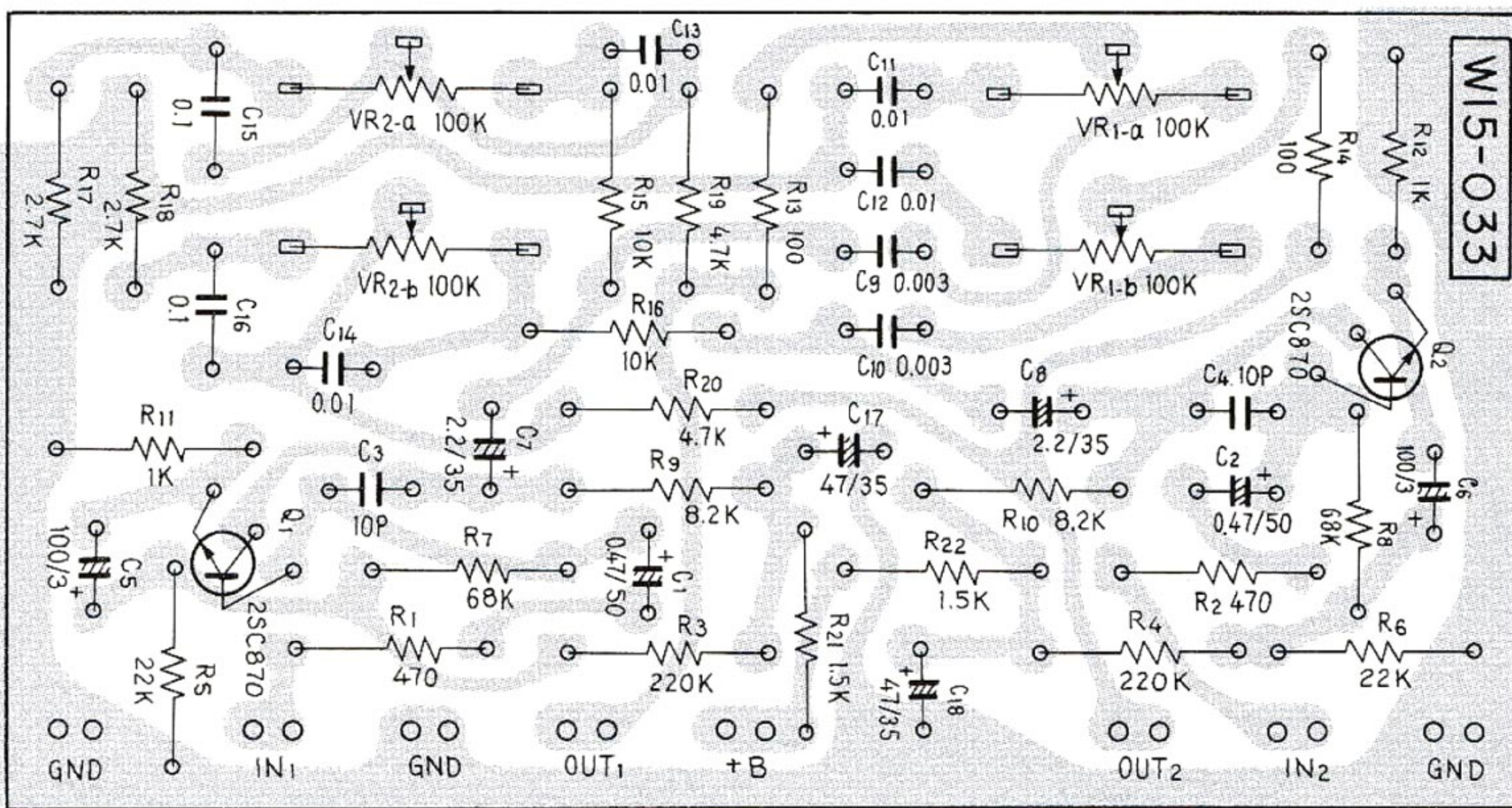

## DIAL CORD STRINGING

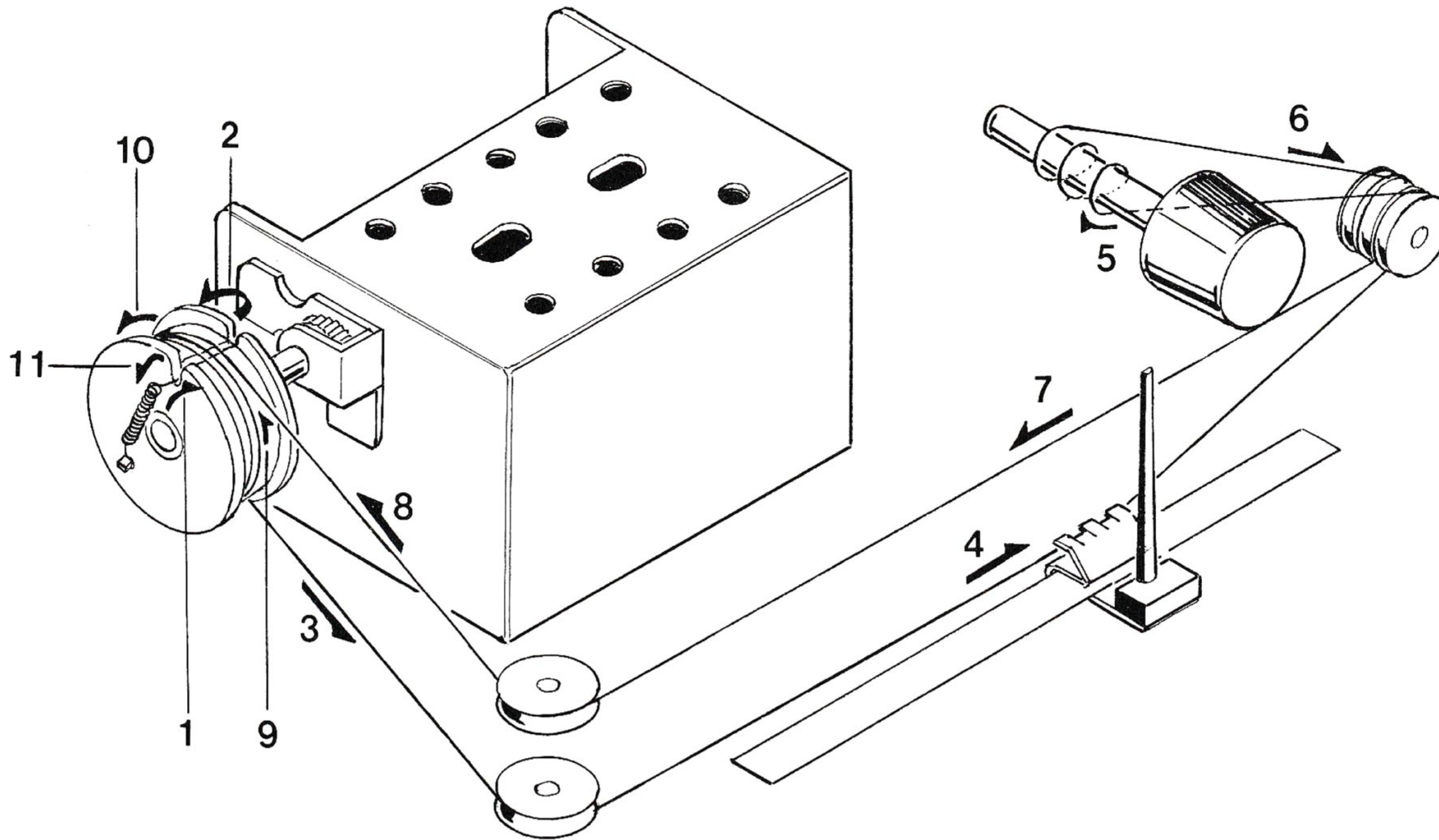

### PIONEER ELECTRONIC CORPORATION

15-5, 4-Chome, Ohmori-nishi, Ohta-ku, Tokyo, Japan

PIONEER ELECTRONICS U.S.A. CORPORATION

140 Smith St., Farmingdale, L.I., N.Y. 11735, U.S.A.

PIONEER ELECTRONIC (EUROPE) AG.

59, Forch Strasse, 8032 Zurich, Switzerland